

# ADJUSTABLE ALUMINUM GANTRY CRANE - AHA-2-15-8

APPROX WEIGHT: 360 lbs.  
DOES NOT INCLUDE WEIGHT OF POWER OR PACKAGING!!!

\*\*\* ANY ADDITIONS, DELETIONS, OR OMISSIONS MUST BE CORRECTED ON THIS DRAWING AS THIS DRAWING WILL BE CONSIDERED ALL INCLUSIVE \*\*\*

ALL GRAPHICS PROVIDED ARE FOR REFERENCE ONLY. IF CERTAIN DIMENSIONS ARE CRITICAL PLEASE VERIFY THOSE DIMENSIONS WITH YOUR SALESPERSON

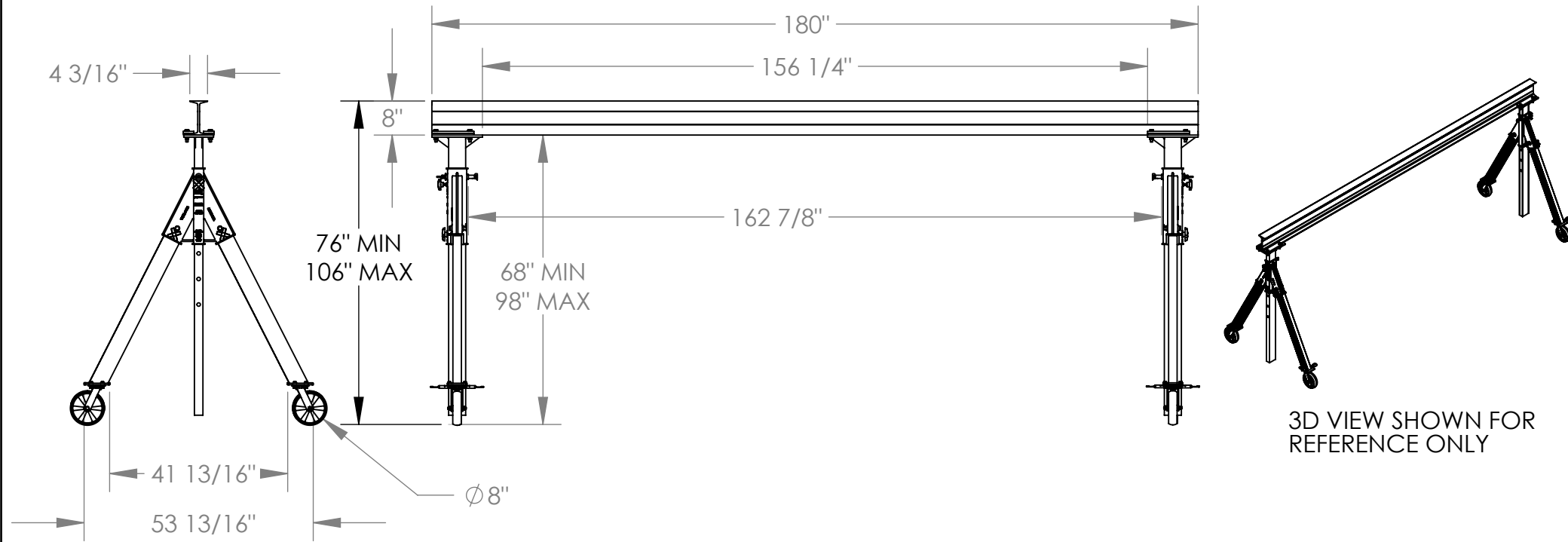

## STANDARD FEATURES

MODEL NUMBER IS AHA-2-15-8  
CAPACITY IS 2,000 LBS.  
BASE WIDTH IS 53 13/16"  
MAX OVERALL HEIGHT IS 106"  
I-BEAM HEIGHT IS 8"  
I-BEAM FLANGE WIDTH IS 4 3/16"  
OVERALL I-BEAM LENGTH IS 180"  
USABLE I-BEAM LENGTH IS 156 1/4"  
ADJUSTABLE UNDER I-BEAM HEIGHT

68" MIN

98" MAX

HEIGHT IS ADJUSTABLE IN 6" INCREMENTS

CASTERS: (4)  $\phi 8"$  X 2" WIDE GLASS FILLED  
NYLON SWIVEL CASTERS WITH FOUR  
LOCKING POSITIONS

## SPECIAL FEATURES

NONE

### DIMENSION TOLERANCE $\pm 1/4"$

I, THE UNDERSIGNED, AGREE THAT THE PRODUCT AS REPRESENTED SATISFIES DESIGN AND DIMENSION REQUIREMENTS. I ALSO ACKNOWLEDGE MY DUTY TO CONFIRM PRODUCT AND INSTALLATION COMPLIANCE WITH ALL APPLICABLE FEDERAL, STATE AND LOCAL REGULATIONS AND STANDARDS.

**ANY MODIFIED UNITS ARE NON-RETURNABLE**

[ ] As drawn [ ] As marked

Signed: \_\_\_\_\_ Date: \_\_\_\_\_

Printed Name: \_\_\_\_\_

LEAD TIME WILL START UPON RECEIPT OF SIGNED APPROVAL DRAWING

APPROVAL

FOR INTERNAL USE ONLY PROJECT SIGN OFF	
SALES	
ENG.	
FAB.	
POWER	

DISTRIBUTOR'S NAME:		P.O.#
VESTIL MANUFACTURING		X
DRAWN BY: ND		W.O.#
DATE: 01/08/08		X
REFERENCE: X	SCALE: 1:34	SALES: X
QUOTED LEAD TIME: X	QUOTE #	FILE NAME:
	X	28-007-193