

ADJUSTABLE STEEL GANTRY CRANE - AHS-6-15-7

APPROX WEIGHT: 767.94 lbs.
 DOES NOT INCLUDE WEIGHT OF POWER OR PACKAGING!!!

*** ANY ADDITIONS, DELETIONS, OR OMISSIONS MUST BE CORRECTED ON THIS DRAWING AS THIS DRAWING WILL BE CONSIDERED ALL INCLUSIVE ***

ALL GRAPHICS PROVIDED ARE FOR REFERENCE ONLY. IF CERTAIN DIMENSIONS ARE CRITICAL PLEASE VERIFY THOSE DIMENSIONS WITH YOUR SALESPERSON

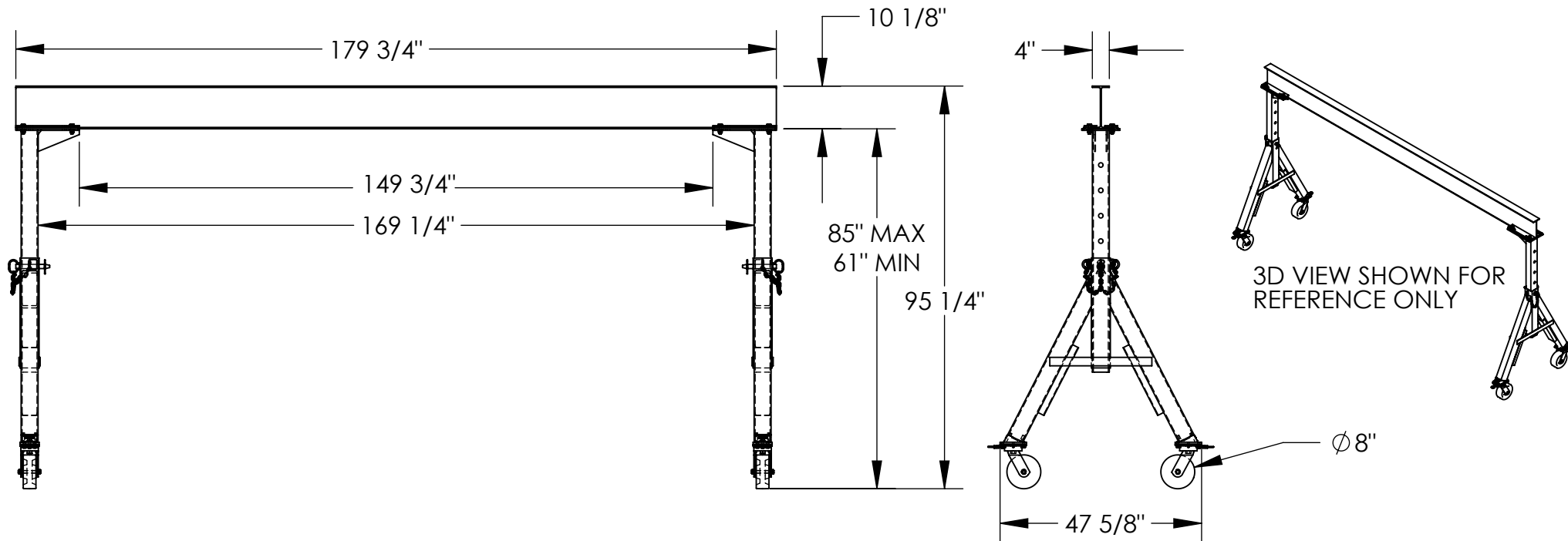

STANDARD FEATURES

- MODEL NUMBER IS AHS-6-15-7
- CAPACITY IS 6,000 LBS.
- BASE WIDTH IS 47 5/8"
- MAX OVERALL HEIGHT IS 95 1/4"
- I-BEAM HEIGHT IS 10 1/8"
- I-BEAM FLANGE WIDTH IS 4"
- OVERALL I-BEAM LENGTH IS 179 3/4"
- USABLE I-BEAM LENGTH IS 149 3/4"
- ADJUSTABLE UNDER I-BEAM HEIGHT
 - 85" MAX
 - 61" MIN
- HEIGHT IS ADJUSTABLE IN 6" INCREMENTS
- CASTERS: (4) Ø8" X 3" WIDE PHENOLIC SWIVEL CASTERS WITH FOUR LOCKING POSITIONS

SPECIAL FEATURES

NONE

DIMENSION TOLERANCE ± 1/4"

A P P R O V A L	I, THE UNDERSIGNED, AGREE THAT THE PRODUCT AS REPRESENTED SATISFIES DESIGN AND DIMENSION REQUIREMENTS. I ALSO ACKNOWLEDGE MY DUTY TO CONFIRM PRODUCT AND INSTALLATION COMPLIANCE WITH ALL APPLICABLE FEDERAL, STATE AND LOCAL REGULATIONS AND STANDARDS.	
	ANY MODIFIED UNITS ARE NON-RETURNABLE	
	[] As drawn [] As marked	
	Signed: _____	Date: _____
Printed Name: _____		
LEAD TIME WILL START UPON RECEIPT OF SIGNED APPROVAL DRAWING		

FOR INTERNAL USE ONLY PROJECT SIGN OFF	
SALES	
ENG.	
FAB.	
POWER	

DISTRIBUTOR'S NAME:		P.O.#
VESTIL MANUFACTURING		X
DRAWN BY: ND	DATE: 10/12/2009	W.O.#
REFERENCE: X	SCALE: 1:35	X
QUOTED LEAD TIME: X	QUOTE #	FILE NAME:
	X	28-007-210