

ADJUSTABLE STEEL GANTRY CRANE - AHS-6-20-14

APPROX WEIGHT: 1410.02 lbs.
 DOES NOT INCLUDE WEIGHT OF POWER OR PACKAGING!!!

*** ANY ADDITIONS, DELETIONS, OR OMISSIONS MUST BE CORRECTED ON THIS DRAWING AS THIS DRAWING WILL BE CONSIDERED ALL INCLUSIVE ***

ALL GRAPHICS PROVIDED ARE FOR REFERENCE ONLY. IF CERTAIN DIMENSIONS ARE CRITICAL PLEASE VERIFY THOSE DIMENSIONS WITH YOUR SALESPERSON

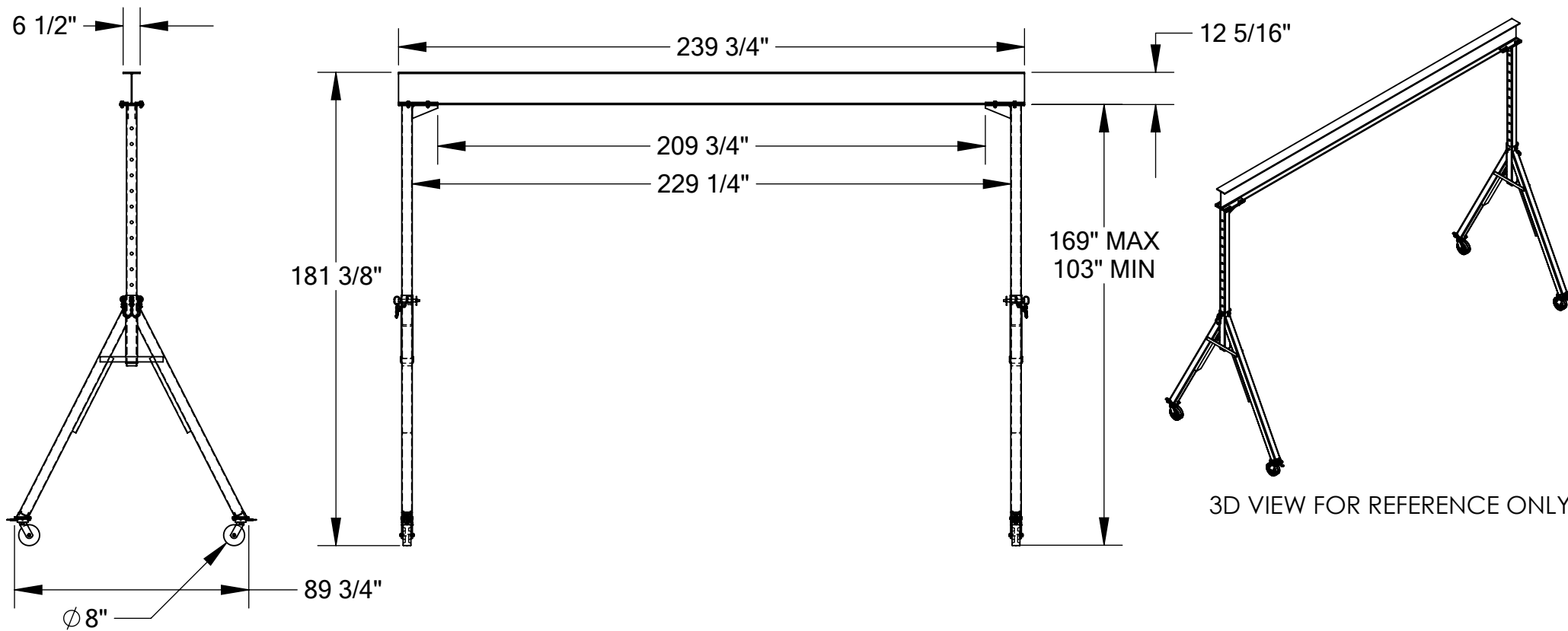

STANDARD FEATURES

- MODEL NUMBER IS AHS-6-20-14
- CAPACITY IS 6,000 LBS.
- BASE WIDTH IS $89\frac{3}{4}$ "
- MAX OVERALL HEIGHT IS $181\frac{3}{8}$ "
- I-BEAM HEIGHT IS $12\frac{5}{16}$ "
- I-BEAM FLANGE WIDTH IS $6\frac{1}{2}$ "
- OVERALL I-BEAM LENGTH IS $239\frac{3}{4}$ "
- USABLE I-BEAM LENGTH IS $209\frac{3}{4}$ "
- ADJUSTABLE UNDER I-BEAM HEIGHT
- $169"$ MAX
- $103"$ MIN
- HEIGHT IS ADJUSTABLE IN 6" INCREMENTS
- CASTERS: (4) $\varnothing 8"$ X 3" WIDE PHENOLIC SWIVEL CASTERS WITH FOUR LOCKING POSITIONS

SPECIAL FEATURES

NONE

DIMENSION TOLERANCE $\pm 1/4"$

A
P
R
O
V
A
L

I, THE UNDERSIGNED, AGREE THAT THE PRODUCT AS REPRESENTED SATISFIES DESIGN AND DIMENSION REQUIREMENTS. I ALSO ACKNOWLEDGE MY DUTY TO CONFIRM PRODUCT AND INSTALLATION COMPLIANCE WITH ALL APPLICABLE FEDERAL, STATE AND LOCAL REGULATIONS AND STANDARDS.

ANY MODIFIED UNITS ARE NON-RETURNABLE

[] As drawn [] As marked

Signed: _____ Date: _____

Printed Name: _____

LEAD TIME WILL START UPON RECEIPT OF SIGNED APPROVAL DRAWING

FOR INTERNAL USE ONLY PROJECT SIGN OFF	
SALES	
ENG.	
FAB.	
POWER	

DISTRIBUTOR'S NAME:		P.O.#
VESTIL MANUFACTURING		X
W.O.#		X
DRAWN BY: ND	DATE: 10/01/09	SALES: X
REFERENCE: X	SCALE: 1:56	FILE NAME:
QUOTED LEAD TIME: X	QUOTE # X	28-007-085