

# FIXED STEEL GANTRY CRANE - FHS-4-15

APPROX WEIGHT: 855 lbs.  
DOES NOT INCLUDE WEIGHT OF POWER OR PACKAGING!!!

\*\*\* ANY ADDITIONS, DELETIONS, OR OMISSIONS MUST BE CORRECTED ON THIS DRAWING AS THIS DRAWING WILL BE CONSIDERED ALL INCLUSIVE \*\*\*

ALL GRAPHICS PROVIDED ARE FOR REFERENCE ONLY. IF CERTAIN DIMENSIONS ARE CRITICAL PLEASE VERIFY THOSE DIMENSIONS WITH YOUR SALESPERSON

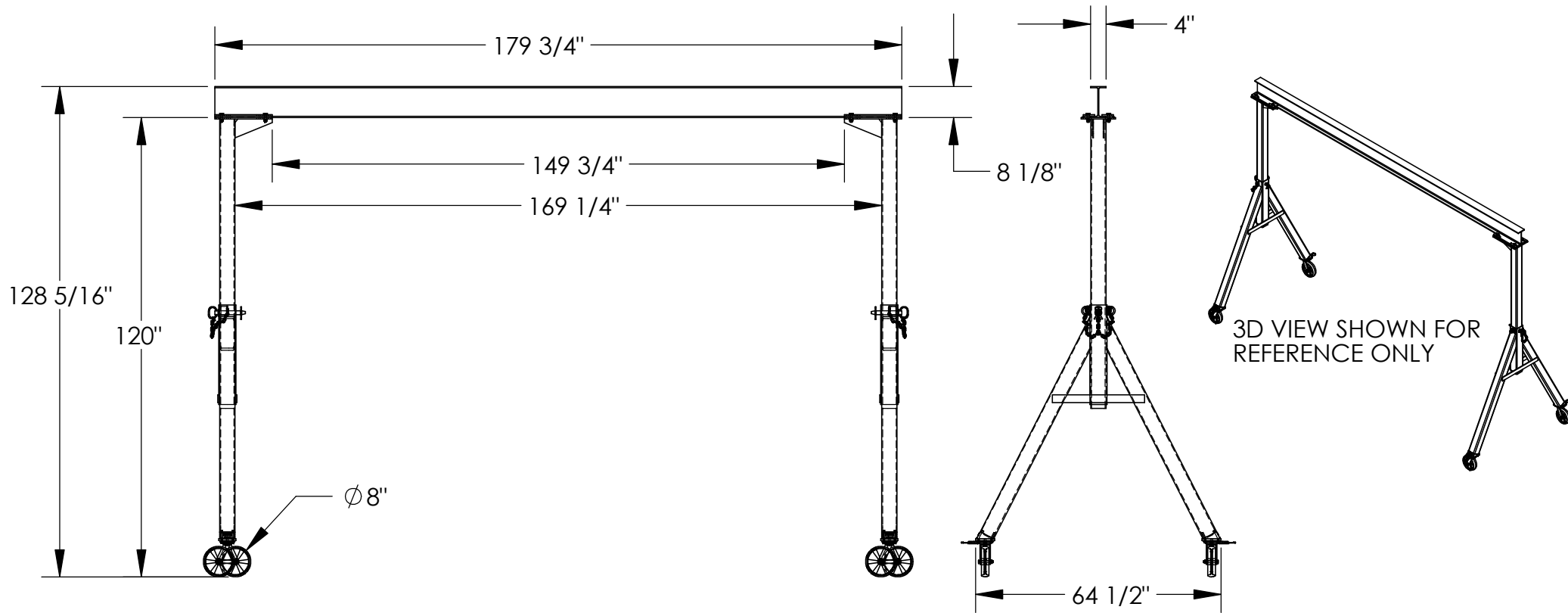

**DIMENSION TOLERANCE ± 1/4"**

I, THE UNDERSIGNED, AGREE THAT THE PRODUCT AS REPRESENTED SATISFIES DESIGN AND DIMENSION REQUIREMENTS. I ALSO ACKNOWLEDGE MY DUTY TO CONFIRM PRODUCT AND INSTALLATION COMPLIANCE WITH ALL APPLICABLE FEDERAL, STATE AND LOCAL REGULATIONS AND STANDARDS.

**ANY MODIFIED UNITS ARE NON-RETURNABLE**

[ ] As drawn [ ] As marked

Signed: \_\_\_\_\_ Date: \_\_\_\_\_

Printed Name: \_\_\_\_\_

LEAD TIME WILL START UPON RECEIPT OF SIGNED APPROVAL DRAWING

**APPROVAL**

## STANDARD FEATURES

- MODEL NUMBER IS FHS-4-15
- CAPACITY IS 4,000 LBS.
- BASE WIDTH IS 64 1/2"
- OVERALL HEIGHT IS 128 5/16"
- I-BEAM HEIGHT IS 8 1/8"
- I-BEAM FLANGE WIDTH IS 4"
- OVERALL I-BEAM LENGTH IS 179 3/4"
- USABLE I-BEAM LENGTH IS 149 3/4"
- UNDER I-BEAM HEIGHT IS 120"
- CASTERS: (4) Ø8" X 2" WIDE GLASS FILLED NYLON SWIVEL CASTERS WITH FOUR LOCKING POSITIONS

## SPECIAL FEATURES

NONE

FOR INTERNAL USE ONLY PROJECT SIGN OFF	
SALES	
ENG.	
FAB.	
POWER	

DISTRIBUTOR'S NAME:		P.O.#
VESTIL MANUFACTURING		X
W.O.#		X
DRAWN BY: MTS	DATE: 08/18/2014	SALES: X
REFERENCE: X	SCALE: 1:38	FILE NAME:
QUOTED LEAD TIME: X	QUOTE # X	28-007-354