

FIXED STEEL GANTRY CRANE - FHS-6-20

APPROX WEIGHT: 1300 lbs.
 DOES NOT INCLUDE WEIGHT OF POWER OR PACKAGING!!!

*** ANY ADDITIONS, DELETIONS, OR OMISSIONS MUST BE CORRECTED ON THIS DRAWING AS THIS DRAWING WILL BE CONSIDERED ALL INCLUSIVE ***

ALL GRAPHICS PROVIDED ARE FOR REFERENCE ONLY. IF CERTAIN DIMENSIONS ARE CRITICAL PLEASE VERIFY THOSE DIMENSIONS WITH YOUR SALESPERSON

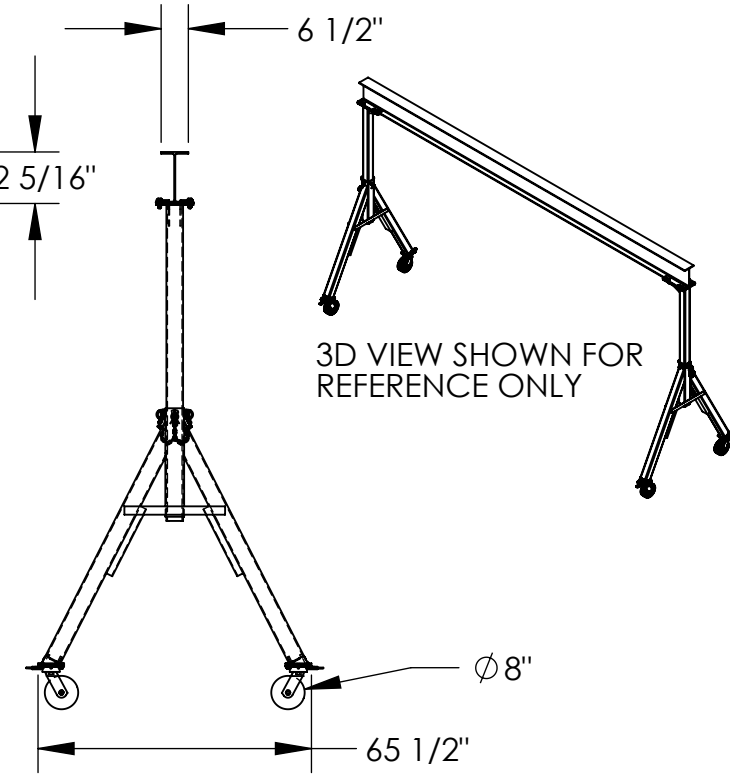
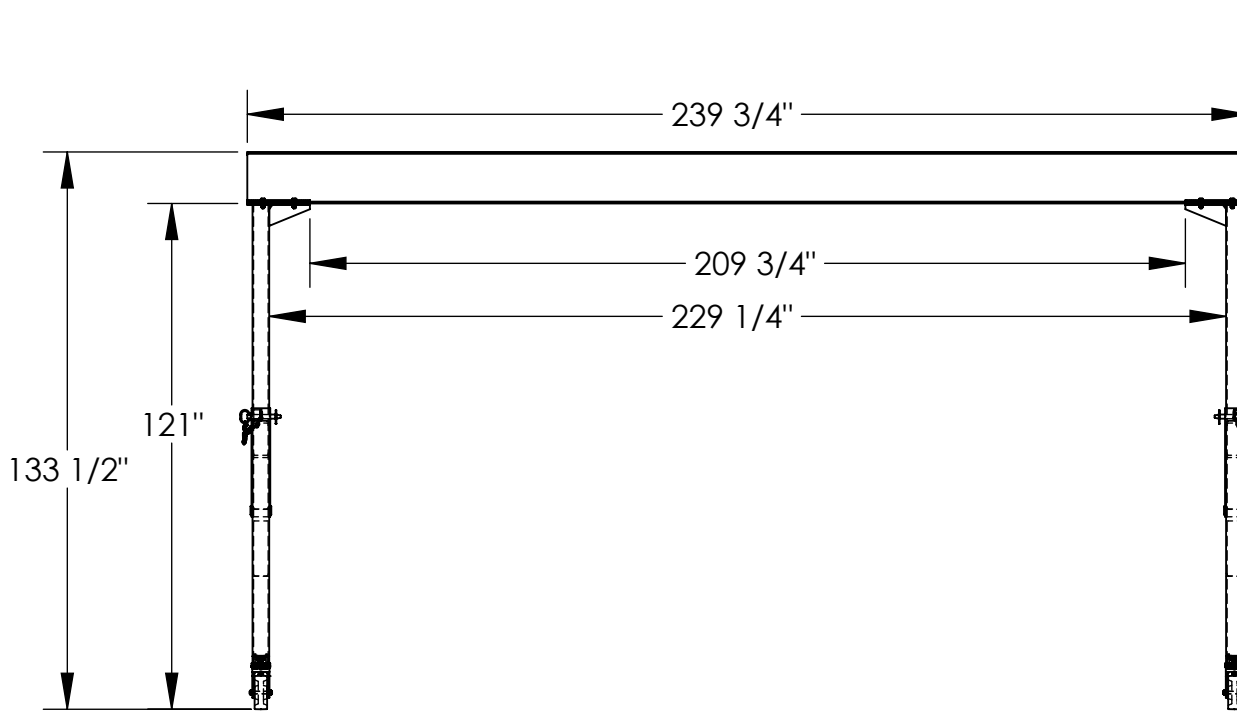

DIMENSION TOLERANCE $\pm 1/4$ "

I, THE UNDERSIGNED, AGREE THAT THE PRODUCT AS REPRESENTED SATISFIES DESIGN AND DIMENSION REQUIREMENTS. I ALSO ACKNOWLEDGE MY DUTY TO CONFIRM PRODUCT AND INSTALLATION COMPLIANCE WITH ALL APPLICABLE FEDERAL, STATE AND LOCAL REGULATIONS AND STANDARDS.

ANY MODIFIED UNITS ARE NON-RETURNABLE

[] As drawn [] As marked

Signed: _____ Date: _____

Printed Name: _____

LEAD TIME WILL START UPON RECEIPT OF SIGNED APPROVAL DRAWING

APPROVAL

STANDARD FEATURES

- MODEL NUMBER IS FHS-6-20
- CAPACITY IS 6,000 LBS.
- BASE WIDTH IS 65 1/2"
- OVERALL HEIGHT IS 133 1/2"
- I-BEAM HEIGHT IS 12 5/16"
- I-BEAM FLANGE WIDTH 6 1/2"
- OVERALL I-BEAM LENGTH IS 239 3/4"
- USABLE I-BEAM LENGTH IS 209 3/4"
- UNDER I-BEAM HEIGHT IS 121"
- CASTERS: (4) $\varnothing 8$ " X 3" WIDE PHENOLIC SWIVEL CASTERS WITH FOUR LOCKING POSITIONS

SPECIAL FEATURES

NONE

FOR INTERNAL USE ONLY PROJECT SIGN OFF	
SALES	
ENG.	
FAB.	
POWER	

DISTRIBUTOR'S NAME:		P.O.#
VESTIL MANUFACTURING		X
DRAWN BY: MTS		W.O.#
DATE: 08/18/2014		X
REFERENCE: X	SCALE: 1:46	SALES: X
QUOTED LEAD TIME: X	QUOTE #	FILE NAME:
	X	28-007-358