

FIXED STEEL GANTRY CRANE - FHS-8-10

APPROX WEIGHT: 865 lbs.
DOES NOT INCLUDE WEIGHT OF POWER OR PACKAGING!!!

*** ANY ADDITIONS, DELETIONS, OR OMISSIONS MUST BE CORRECTED ON THIS DRAWING AS THIS DRAWING WILL BE CONSIDERED ALL INCLUSIVE ***

ALL GRAPHICS PROVIDED ARE FOR REFERENCE ONLY. IF CERTAIN DIMENSIONS ARE CRITICAL PLEASE VERIFY THOSE DIMENSIONS WITH YOUR SALESPERSON

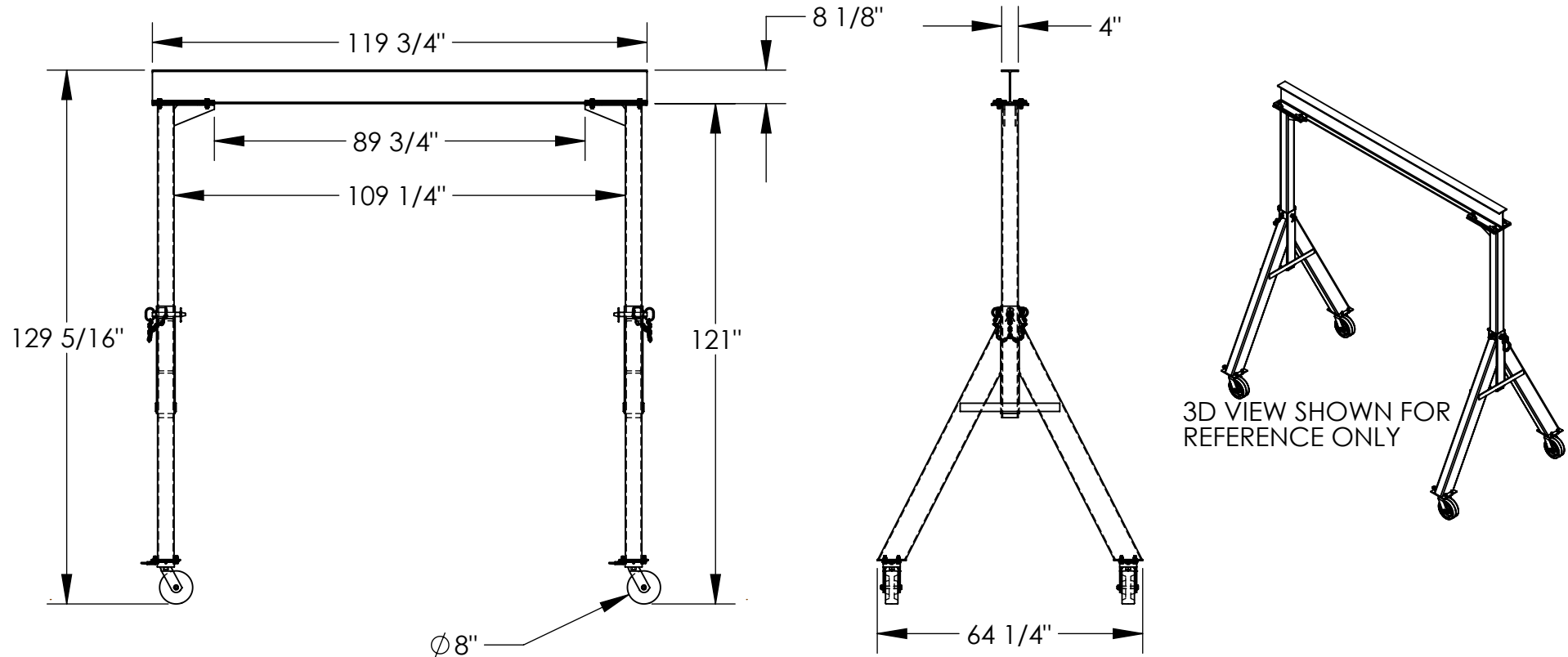

3D VIEW SHOWN FOR REFERENCE ONLY

DIMENSION TOLERANCE ± 1/4"

I, THE UNDERSIGNED, AGREE THAT THE PRODUCT AS REPRESENTED SATISFIES DESIGN AND DIMENSION REQUIREMENTS. I ALSO ACKNOWLEDGE MY DUTY TO CONFIRM PRODUCT AND INSTALLATION COMPLIANCE WITH ALL APPLICABLE FEDERAL, STATE AND LOCAL REGULATIONS AND STANDARDS.

ANY MODIFIED UNITS ARE NON-RETURNABLE

[] As drawn [] As marked

Signed: _____ Date: _____

Printed Name: _____

LEAD TIME WILL START UPON RECEIPT OF SIGNED APPROVAL DRAWING

APPROVAL

STANDARD FEATURES

- MODEL NUMBER IS FHS-8-10
- CAPACITY IS 8,000 LBS.
- BASE WIDTH IS 64 1/4"
- OVERALL HEIGHT IS 129 5/16"
- I-BEAM HEIGHT IS 8 1/8"
- I-BEAM FLANGE WIDTH 4"
- OVERALL I-BEAM LENGTH IS 119 3/4"
- USABLE I-BEAM LENGTH IS 89 3/4"
- UNDER I-BEAM HEIGHT IS 121"
- CASTERS: (4) Ø8" X 3" WIDE PHENOLIC SWIVEL CASTERS WITH FOUR LOCKING POSITIONS

SPECIAL FEATURES

NONE

FOR INTERNAL USE ONLY
PROJECT SIGN OFF

SALES	
ENG.	
FAB.	
POWER	

DISTRIBUTOR'S NAME:		P.O.#
VESTIL MANUFACTURING		X
DRAWN BY:	DATE:	W.O.#
MTS	08/19/2014	X
REFERENCE:	SCALE:	SALES:
X	1:38	X
QUOTED LEAD TIME:	QUOTE #	FILE NAME:
X	X	28-007-359