

# SHELF DRUM CHOCK - VDRCH-2-GRN

APPROX WEIGHT: 5 lbs.  
 DOES NOT INCLUDE WEIGHT OF POWER OR PACKAGING!!!

\*\*\* ANY ADDITIONS, DELETIONS, OR OMISSIONS MUST BE CORRECTED ON THIS DRAWING AS THIS DRAWING WILL BE CONSIDERED ALL INCLUSIVE \*\*\*

ALL GRAPHICS PROVIDED ARE FOR REFERENCE ONLY. IF CERTAIN DIMENSIONS ARE CRITICAL PLEASE VERIFY THOSE DIMENSIONS WITH YOUR SALESPERSON

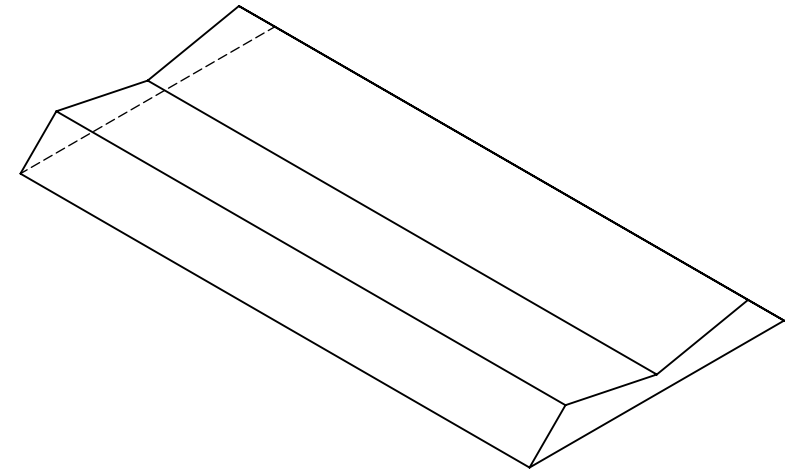
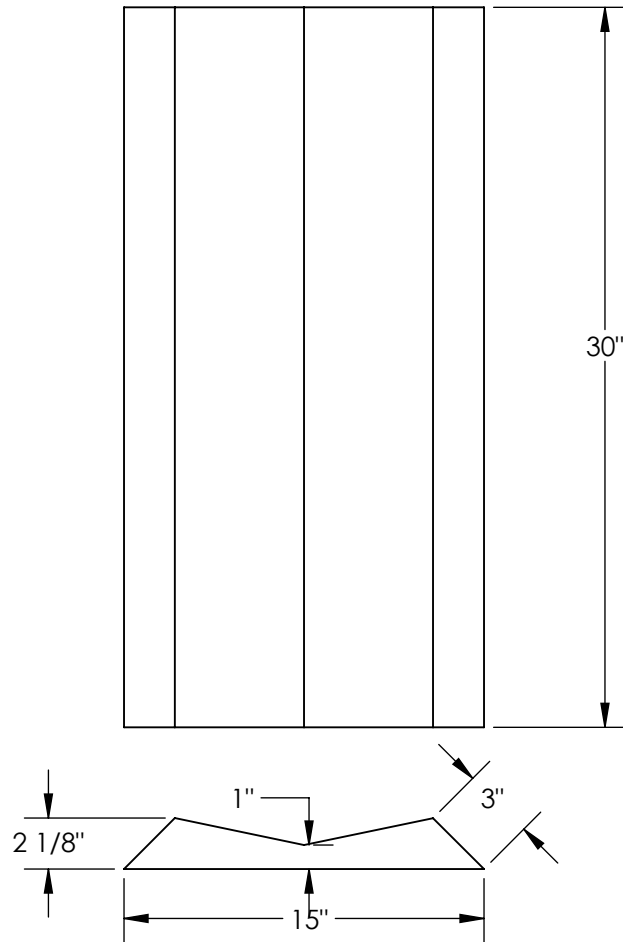

DIMENSION TOLERANCE  $\pm 1/4"$

## STANDARD FEATURES

MODEL NUMBER IS VDRCH-2-GRN  
 OVERALL WIDTH IS 15"  
 OVERALL LENGTH IS 30"  
 OVERALL HEIGHT IS 2 1/8"  
 WEIGHT 5 LBS. EACH  
 MAX CAPACITY IS 550 LBS. EACH  
 TWO PER BOX  
 MADE OF 100% RECYCLED MATERIAL

## SPECIAL FEATURES

NONE

<b>APPROVAL</b>	I, THE UNDERSIGNED, AGREE THAT THE PRODUCT AS REPRESENTED SATISFIES DESIGN AND DIMENSION REQUIREMENTS. I ALSO ACKNOWLEDGE MY DUTY TO CONFIRM PRODUCT AND INSTALLATION COMPLIANCE WITH ALL APPLICABLE FEDERAL, STATE AND LOCAL REGULATIONS AND STANDARDS.	
	<b>ALL SPECIAL UNITS ARE NON-RETURNABLE</b> <input type="checkbox"/> As drawn <input type="checkbox"/> As marked	
	Signed: _____	Date: _____
<b>LEAD TIME WILL START UPON RECEIPT OF SIGNED APPROVAL DRAWING</b>		

DISTRIBUTOR'S NAME:		P.O.#
<b>VESTIL MANUFACTURING</b>		X
DRAWN BY: RPS	DATE: 09/27/2012	W.O.#
REFERENCE: X	SCALE: 1:8	X
QUOTED LEAD TIME: X	QUOTE #	FILE NAME:
	X	31-007-187-001