

# POWER LIFT JIB CRANE-WTJ-20-4-AC-GAL

APPROX WEIGHT: 371.96 lbs. DOES NOT INCLUDE WEIGHT OF POWER OR PACKAGING!!!

\*\*\*ANY ADDITIONS, DELETIONS, OR OMISSIONS MUST BE CORRECTED ON THIS DRAWING AS THIS DRAWING WILL BE CONSIDERED ALL INCLUSIVE\*\*\*  
 \*\*\*ALL GRAPHICS PROVIDED ARE FOR REFERENCE ONLY. IF CERTAIN DIMENSIONS ARE CRITICAL PLEASE VERIFY THOSE DIMENSIONS WITH YOUR SALESPERSON\*\*\*

## BOOM CAPACITY CHART WTJ-20-4

BOOM POSITION	BOOM EXTENSION			
	FULLY RETRACTED	SECOND POSITION	THIRD POSITION	FULLY EXTENDED
A	1100 LBS	800 LBS	600 LBS	250 LBS
B	1500 LBS	1200 LBS	1000 LBS	600 LBS
C	1850 LBS	1450 LBS	1250 LBS	780 LBS
D	2000 LBS	2000 LBS	1900 LBS	1200 LBS

**SPECIAL FOUNDATION MAY BE REQUIRED, SEE OWNERS MANUAL FOR DETAILS. UNIT IS DESIGNED FOR VERTICAL LIFTING ONLY. DO NOT USE FOR LIFTING PERSONNEL OR FOR OVERHEAD LIFTING.**

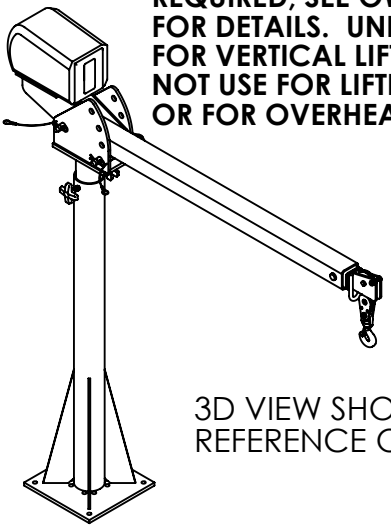

3D VIEW SHOWN FOR REFERENCE ONLY

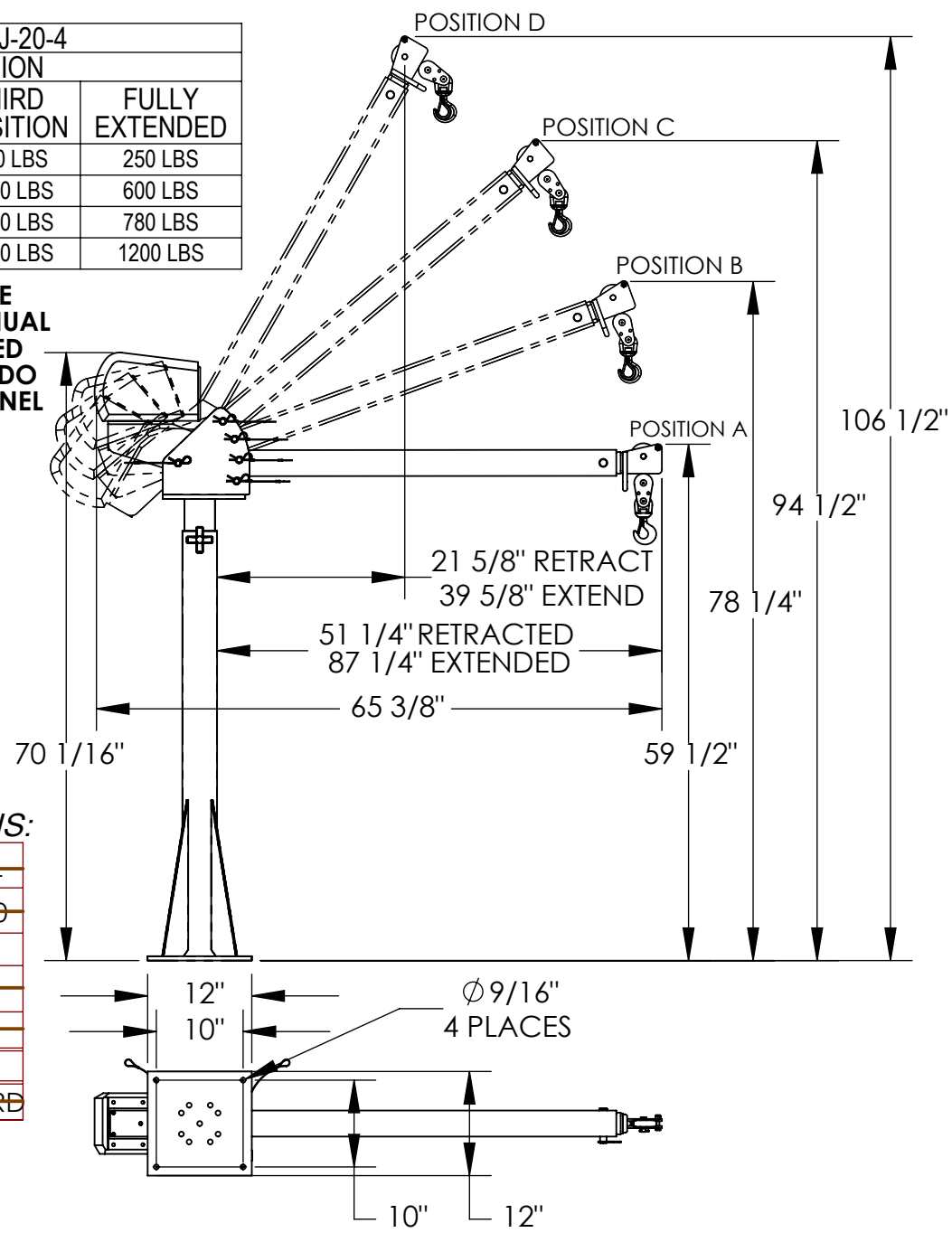

### PLEASE CIRCLE SPECIFICATIONS:

POWER	AC	DC (12V)	AIR/OIL
MOTOR VOLTAGE	115	208	230 460
DEDICATED CIRCUIT REQUIRED			
MOTOR PHASE	SINGLE	THREE	
* CONTROL	HAND	FOOT	
~ ALL BATTERY CHARGERS ARE 115V AC ~			
* BATTERY CHRG.	REMOTE	ON BOARD	

\* AVAILABLE AT ADDITIONAL COST

## STANDARD FEATURES

- MODEL NUMBER IS: WTJ-20-4-AC-GAL
- CAPACITY IS: 2,000 LBS.
- OVERALL WIDTH IS: 12"
- OVERALL RETRACTED LENGTH IS: 65 3/8"
- USABLE RETRACTED LENGTH IS: 51 1/4"
- USABLE EXTENDED LENGTH IS: 87 1/4"
- OVERALL HEIGHT IS: 70 1/16"
- OVERALL STORAGE HEIGHT IS: 73"
- 115V AC POWERED WINCH
- WITH FINGER TIP TOGGLE SWITCH
- Ø7/32" X 25' LG CABLE AND HOOK
- HOT DIPPED GALVANIZED FINISH

## SPECIAL FEATURES

NONE

I, THE UNDERSIGNED, AGREE THAT THE PRODUCT AS REPRESENTED SATISFIES DESIGN AND DIMENSION REQUIREMENTS. I ALSO ACKNOWLEDGE MY DUTY TO CONFIRM PRODUCT AND INSTALLATION COMPLIANCE WITH ALL APPLICABLE FEDERAL, STATE AND LOCAL REGULATIONS AND STANDARDS.

**ALL SPECIAL UNITS ARE NON-RETURNABLE**  
 [ ] As drawn [ ] As marked

Signed: \_\_\_\_\_ Date: \_\_\_\_\_

LEAD TIME WILL START UPON RECEIPT OF SIGNED APPROVAL DRAWING

DISTRIBUTOR'S NAME:		P.O.#
VESTIL MANUFACTURING		X
DRAWN BY: ND		DATE: 12/6/14
DATE: 12/6/14		SALES: X
REFERENCE: X	SCALE: 1:20	FILE NAME:
QUOTED LEAD TIME: X	QUOTE # X	28-007-369