

SWIVEL BASE LIFTING CRANE WITH WINCH

MODEL: WTJ - 4

CAPACITY: 2000 LBS

Parts Diagram

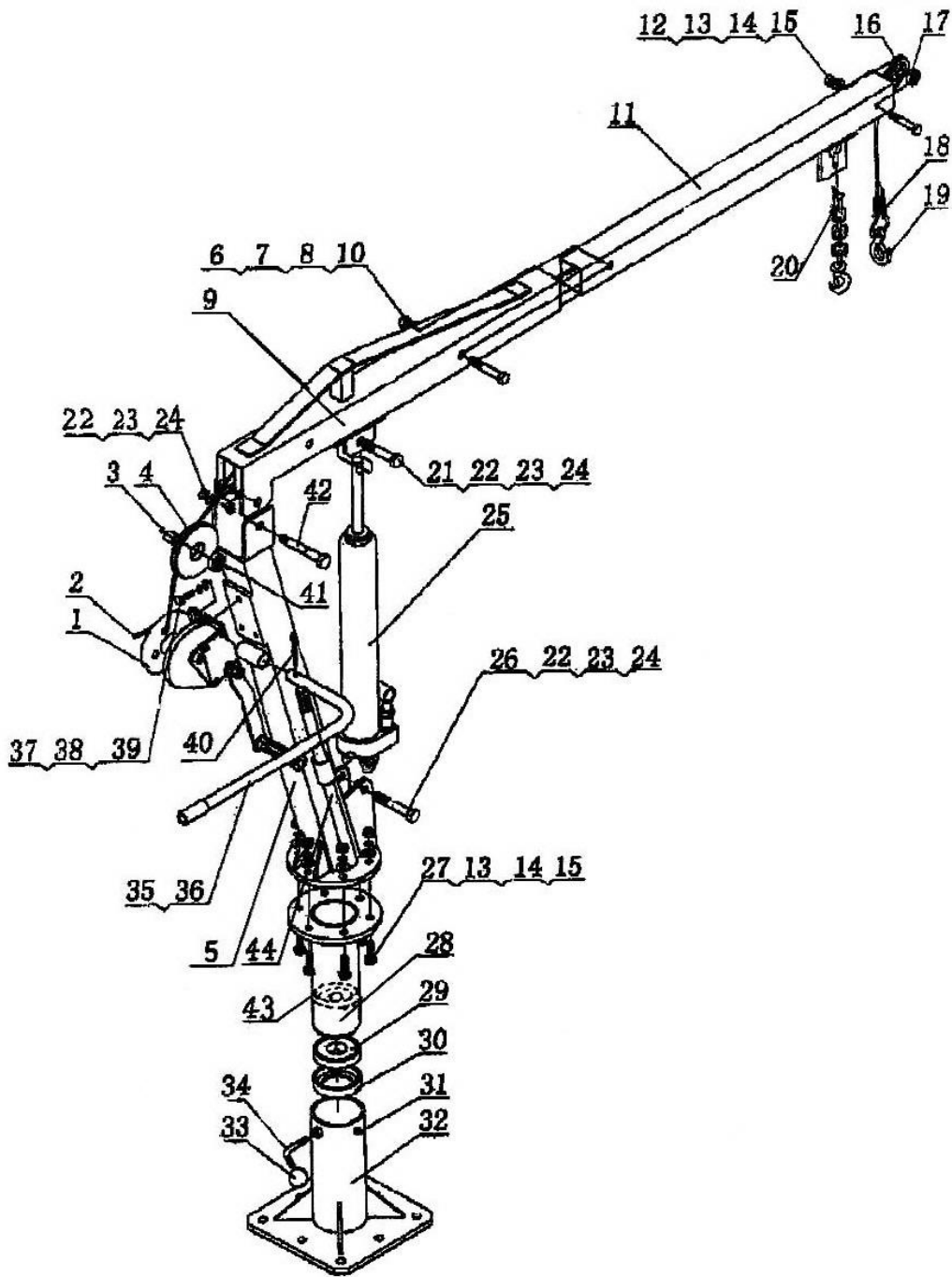

Ref No.	Description	QTY	Ref No.	Description	QTY	Ref No.	Description	QTY
1	Winch Assembly	1	16	Small Pulley	1	31	Grease Fitting	1
2	Winch Wire	1	17	Bearing	1	32	Base	1
3	Bushing	1	18	Wire Clamp	2	33	Bakelite Nut	1
4	Large Pulley	1	19	Hook Subassembly	1	34	Binding Bolt	1
5	Post Weldment	1	20	Hook with Bolt	1	35	Handle	1
6	Nut M14	1	21	Bolt M16x80	1	36	Handle Cover	1
7	Lock Washer ϕ 14	1	22	Nut M16	3	37	Bolt M10x20	3
8	Flat Washer ϕ 14	1	23	Lock Washer ϕ 16	3	38	Lock Washer ϕ 10	3
9	Boom	1	24	Flat Washer ϕ 16	3	39	Flat Washer ϕ 10	3
10	Bolt M14x100	1	25	3T Jack	1	40	R pin	1
11	Boom Extension	1	26	Bolt M16x90	1	41	Bearing	1
12	Bolt M12x85	1	27	Bolt M12x40	6	42	Bolt M16x110	1
13	Nut M12	7	28	Turntable	1	43	Bearing	1
14	Lock Washer ϕ 12	7	29	Bearing ϕ 40	1	44	3T Jack Handle	1
15	Flat Washer ϕ 12	7	30	Bearing Sleeve	1			

WARNING!

Read all the instructions and warnings first before attempting to operate this lifting crane.

1. Do not operate the hydraulic pump beyond rated capacity. Do not exceed winch load weight capacity.
2. Avoid any moving parts while using this lifting crane, keep fingers and hands away from moving parts.
3. Be certain the crane is properly bolted to a truck bed that can hold the load.
4. Never come between the crane and the load when operating.
5. Never fully extend cable while pulling a load, keep 4 complete turns of cable around the winch module.
6. Never operate winch if cable shows any signs of weakening, is knotted or kinked.
7. Never fully extend the cable winch under load.
8. Don't overreach. Keep proper footing and balance at all times.
9. Never lift people or hoist loads over people.
10. Always set parking brake and block tires when using this truck lift. Vehicles with automatic transmissions should be left in "park". Manual transmissions should be left in gear. Never attempt to lift something while the vehicle is moving.
11. Stay Alert. Watch what you are doing. Use common sense. Do not operate any tool when you are tired.

ASSEMBLY INSTRUCTIONS

1. Put the Bearing $\phi 40$ (#29) into the Bearing Sleeve (#30), then assemble them into the Base (#32).
2. Assemble the Turntable (#28) onto the Bearing $\phi 40$ (#29) so that the Turntable (#28) and Base (#32) combined together. Rotate the Turntable (#28) on the base (#32) to make sure the assembly is right.
3. Assemble the Grease Fitting (#31), Binding Bolt (#34) and Bakelite Nut (#33) onto the Base (#32).
4. Assemble the Bearing (#41) into the hole of Large Pulley (#4), then use the Bolt M16X110 (#42) connect the Post Weldment (#5) and Boom (#9), at the same time insert the Bushing (#3) and assembled Large Pulley make sure the assembled Large Pulley is in the middle place, then tighten with Flat Washer $\phi 16$ (#24), Lock Washer $\phi 16$ (#23) and Nut M16 (#22).
5. Assemble the 3T Jack (#25) onto Boom (#9) using Bolt M16X80 (#21), Flat Washer $\phi 16$ (#24), Lock Washer $\phi 16$ (#23) and Nut M16 (#22). Assemble the bottom of the 3T Jack (#25) onto the Post Weldment (#5), using Bolt M16X90 (#26), Flat Washer $\phi 16$ (#24), Lock Washer $\phi 16$ (#23) and Nut M16 (#22).
6. Assemble the Winch (#1) on the Post Weldment (#5) by tightening 3 sets Bolt M10X20 (#37), Lock Washer $\phi 10$ (#38), Flat Washer $\phi 10$ (#39).
7. Put the Handle Cover (#36) onto the long end of Handle (#35), then insert the handle into the hollow sleeve on Post Weldment (#5), locked by the R pin (#40).
8. Assemble the Bearing (#17) into the Small Pulley (#16), then insert the Bolt M12X85 (#12) through Boom Extension (#11), Bearing (#17), and tighten by Flat Washer $\phi 12$ (#15), Lock Washer $\phi 12$ (#14) and Nut M12 (#13).
9. Fix the Base (#32) first, then put the Post Subassembly onto the Base Subassembly connect by using 6 sets Bolt M12X40 (#27), Lock Washer $\phi 12$ (#14), Flat Washer $\phi 12$ (#15) and Nut M12 (#13).
10. Insert the Boom Extension Subassembly into the Boom Subassembly and locked by Bolt M14X100 (#10), Lock Washer $\phi 14$ (#7), Flat Washer $\phi 14$ (#8) and Nut M14 (#6).
11. Insert the one end of Winch Wire (#2) through Small Pulley (#16), Boom Extension (#11), Boom (#9) and Large Pulley (#4), then coil on the rope roll of the Winch (#1), locked the wire end on the side plate of Winch by inserting it through four holes on side plate.