

ADJ WORK-MATE STAND - MODEL: AHT-H-1948-SS

APPROX WEIGHT: 57.45 lbs.
DOES NOT INCLUDE WEIGHT OF POWER OR PACKAGING!!!

*** ANY ADDITIONS, DELETIONS, OR OMISSIONS MUST BE CORRECTED ON THIS DRAWING AS THIS DRAWING WILL BE CONSIDERED ALL INCLUSIVE ***
ALL GRAPHICS PROVIDED ARE FOR REFERENCE ONLY. IF CERTAIN DIMENSIONS ARE CRITICAL PLEASE VERIFY THOSE DIMENSIONS WITH YOUR SALESPERSON

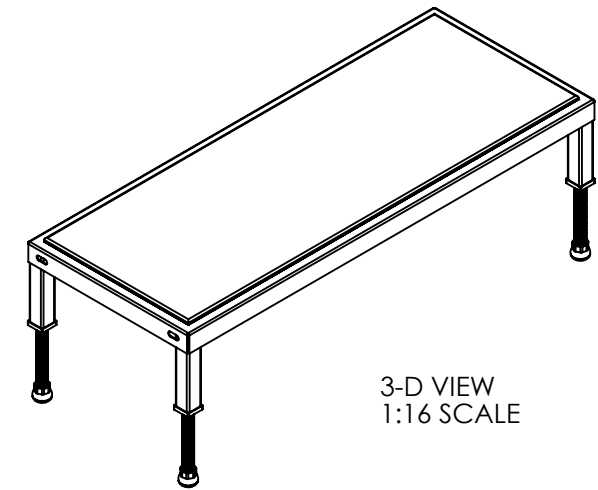
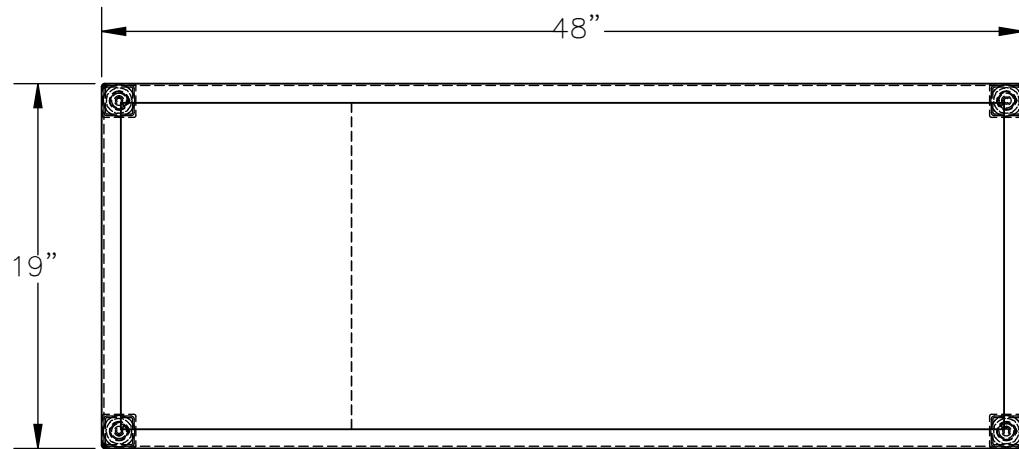

3-D VIEW
1:16 SCALE

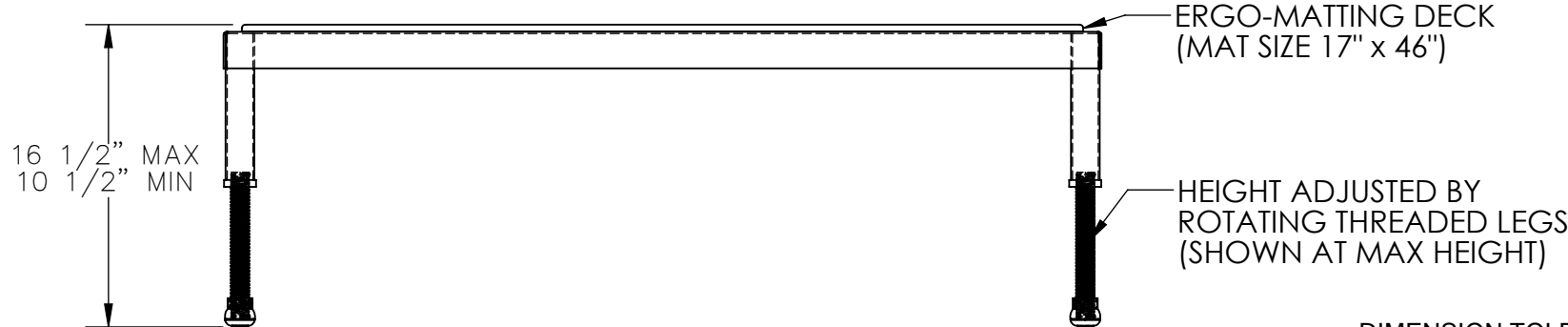

DIMENSION TOLERANCE $\pm 1/4$ "

STANDARD FEATURES

- MODEL NUMBER : AHT-H-1948-SS
- CAPACITY: 500 LBS.
- DECK WIDTH: 19"
- DECK LENGTH: 48"
- RAISED HEIGHT: 16 1/2"
- LOWERED HEIGHT: 10 1/2"
- ALL STAINLESS STEEL CONSTRUCTION WITH WELDING TO MEET AWS.
- ERGO MATting IS BLUE
- STAINLESS STEEL CONSTRUCTION WITH UNPOLISHED (MILL) FINISH

SPECIAL FEATURES

NONE

FOR INTERNAL USE ONLY PROJECT SIGN OFF	
SALES	
ENG.	
FAB.	
POWER	

A P P R O V A L	I, THE UNDERSIGNED, AGREE THAT THE PRODUCT AS REPRESENTED SATISFIES DESIGN AND DIMENSION REQUIREMENTS. I ALSO ACKNOWLEDGE MY DUTY TO CONFIRM PRODUCT AND INSTALLATION COMPLIANCE WITH ALL APPLICABLE FEDERAL, STATE AND LOCAL REGULATIONS AND STANDARDS.	
	ANY MODIFIED UNITS ARE NON-RETURNABLE	
	[] As drawn [] As marked	
	Signed: _____ Date: _____	
Printed Name: _____		
LEAD TIME WILL START UPON RECEIPT OF SIGNED APPROVAL DRAWING		

DISTRIBUTOR'S NAME:		P.O.#
VESTIL MANUFACTURING		X
		W.O.#
DRAWN BY: MTS	DATE: 12/27/13	X
REFERENCE: X	SCALE: 1:10	FILE NAME:
QUOTED LEAD TIME: X	QUOTE # X	14-007-243