

# ADJ WORK-MATE STAND - MODEL: AHT-H-2448

APPROX WEIGHT: 69.37 lbs.  
DOES NOT INCLUDE WEIGHT OF POWER OR PACKAGING!!!

\*\*\* ANY ADDITIONS, DELETIONS, OR OMISSIONS MUST BE CORRECTED ON THIS DRAWING AS THIS DRAWING WILL BE CONSIDERED ALL INCLUSIVE \*\*\*  
ALL GRAPHICS PROVIDED ARE FOR REFERENCE ONLY. IF CERTAIN DIMENSIONS ARE CRITICAL PLEASE VERIFY THOSE DIMENSIONS WITH YOUR SALESPERSON

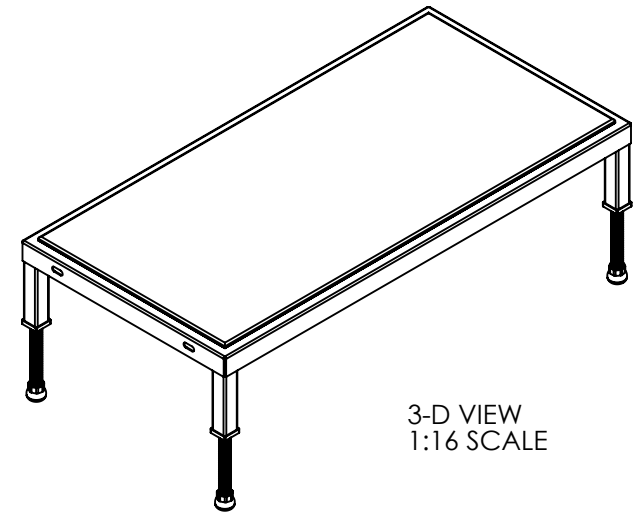
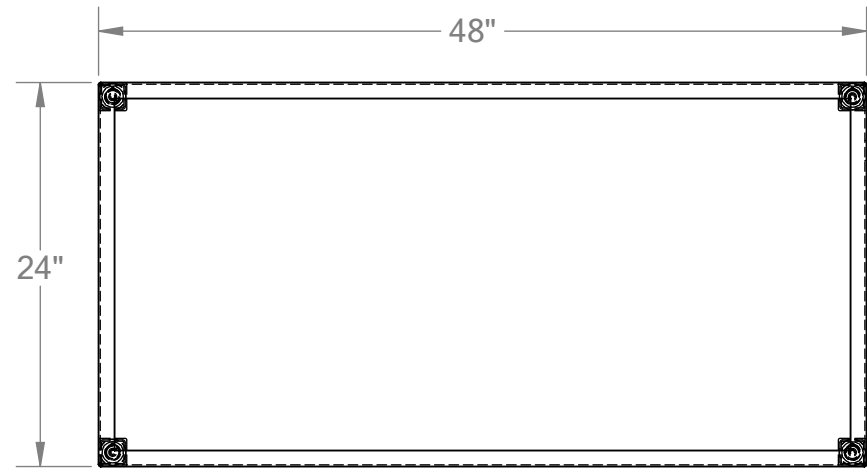

3-D VIEW  
1:16 SCALE

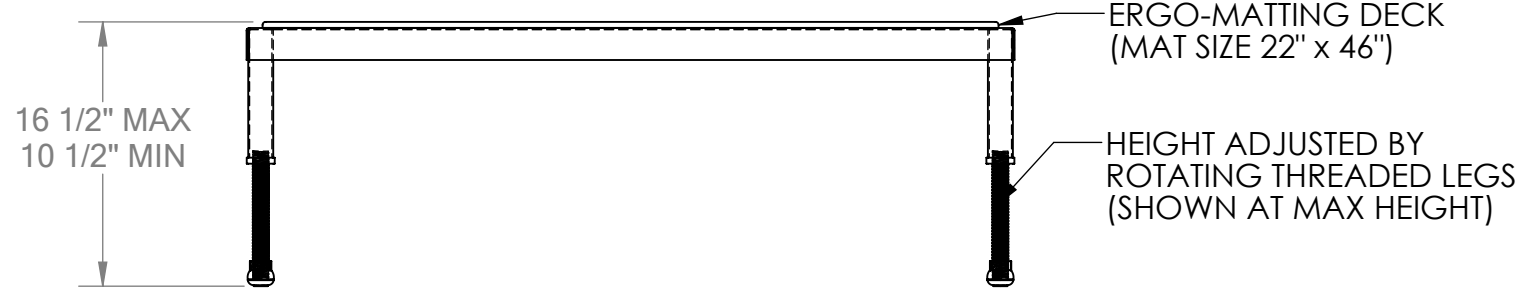

DIMENSION TOLERANCE  $\pm 1/4$ "

## STANDARD FEATURES

- MODEL NUMBER : AHT-H-2448
- CAPACITY: 500 LBS.
- DECK WIDTH: 24"
- DECK LENGTH: 48"
- RAISED HEIGHT: 16 1/2"
- LOWERED HEIGHT: 10 1/2"
- ALL STEEL CONSTRUCTION  
(ASTM A-36 MIN.)  
WITH WELDING TO MEET AWS.
- ERGO MATting IS BLUE
- TOUGH BAKED IN POWDER  
COATED YELLOW FINISH

## SPECIAL FEATURES

NONE

FOR INTERNAL USE ONLY PROJECT SIGN OFF	
SALES	
ENG.	
FAB.	
POWER	

**APPROVAL**

I, THE UNDERSIGNED, AGREE THAT THE PRODUCT AS REPRESENTED SATISFIES DESIGN AND DIMENSION REQUIREMENTS. I ALSO ACKNOWLEDGE MY DUTY TO CONFIRM PRODUCT AND INSTALLATION COMPLIANCE WITH ALL APPLICABLE FEDERAL, STATE AND LOCAL REGULATIONS AND STANDARDS.

**ANY MODIFIED UNITS ARE NON-RETURNABLE**

[ ] As drawn      [ ] As marked

Signed: \_\_\_\_\_ Date: \_\_\_\_\_

Printed Name: \_\_\_\_\_

*LEAD TIME WILL START UPON RECEIPT OF SIGNED APPROVAL DRAWING*

DISTRIBUTOR'S NAME:		P.O.#
VESTIL MANUFACTURING		X
DRAWN BY: MTS		DATE: 12/27/13
REFERENCE: X		SCALE: 1:12
QUOTED LEAD TIME: X	QUOTE #	FILE NAME:
X	X	14-007-210