

GAS POWERED ALL TERRAIN PALLET TRUCK - ALL-T-4-GPT-L-PT

ANY ADDITIONS, DELETIONS, OR OMISSIONS MUST BE CORRECTED ON THIS DRAWING AS THIS DRAWING WILL BE CONSIDERED ALL INCLUSIVE
 APPROX WEIGHT: 1404 lbs.
 DOES NOT INCLUDE WEIGHT OF POWER OR PACKAGING!!!

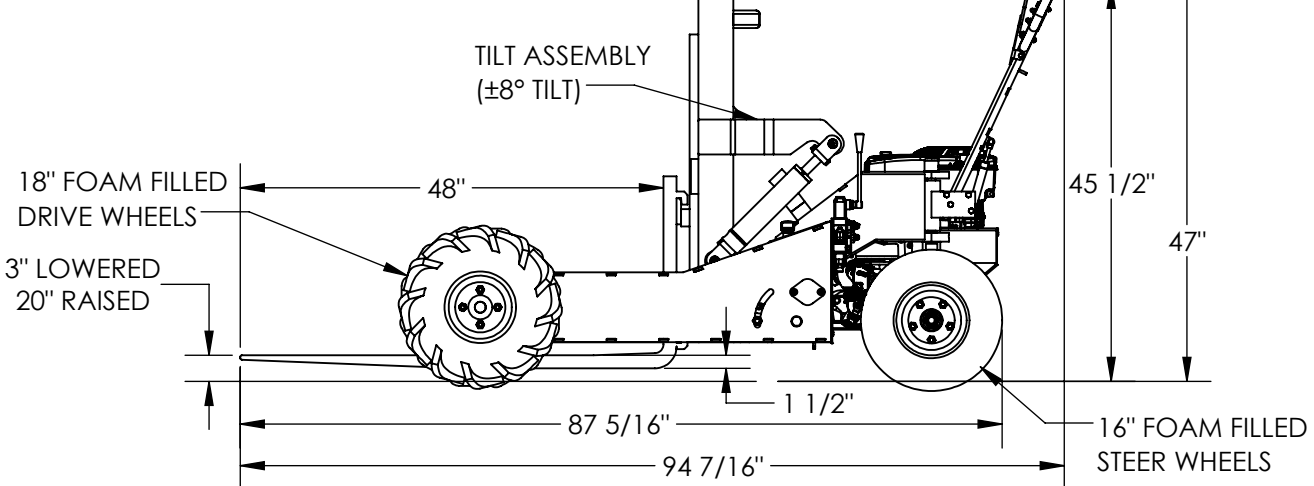
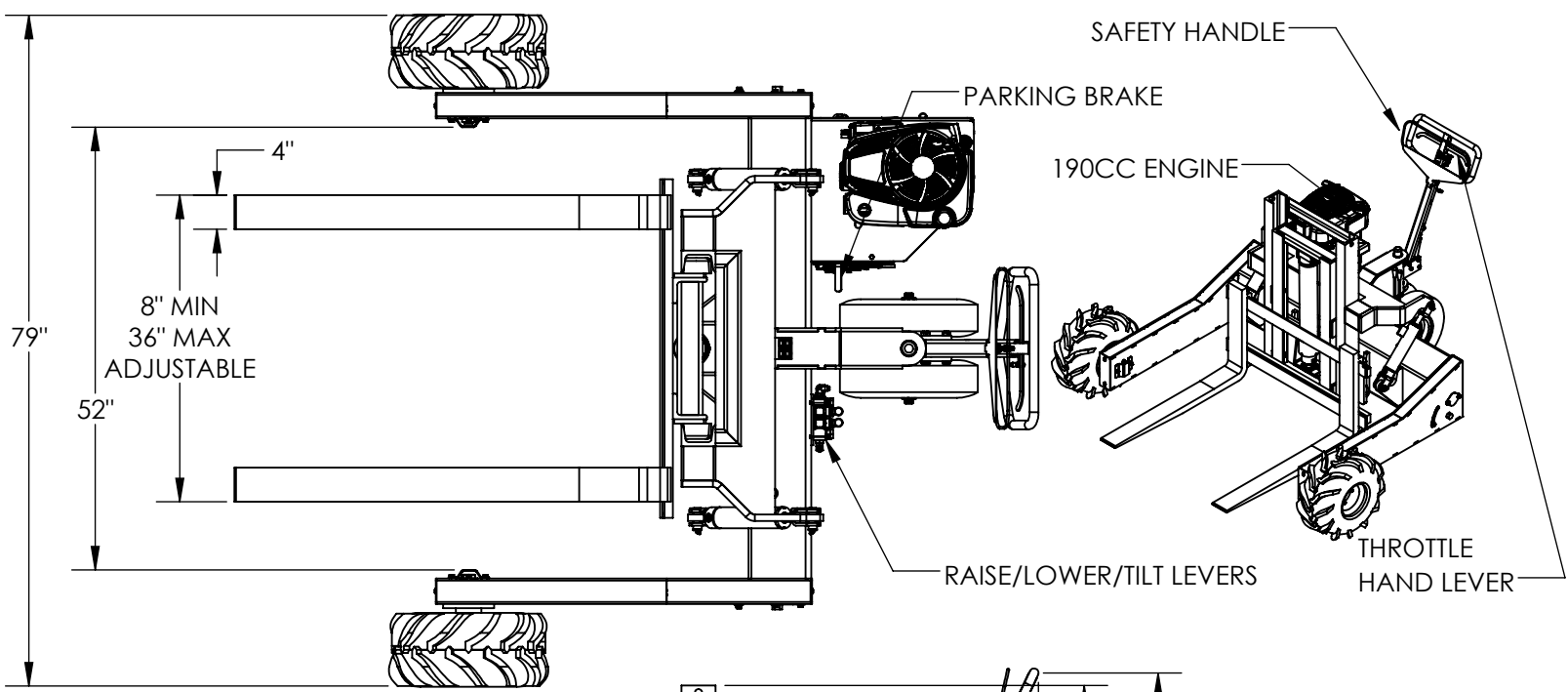

| | |
|---|--|
| FOR INTERNAL USE ONLY PROJECT SIGN OFF | |
| SALES | |
| ENG. | |
| FAB. | |
| POWER | |

ALL GRAPHICS PROVIDED ARE FOR REFERENCE ONLY. IF CERTAIN DIMENSIONS ARE CRITICAL PLEASE VERIFY THOSE DIMENSIONS WITH YOUR SALESPERSON
 DIMENSION TOLERANCE ± 1"

- STANDARD FEATURES**
 MODEL NUMBER IS ALL-T-4-GPT-L-PT
 CAPACITY IS 4,000 LBS
 OVERALL WIDTH IS 79"
 STRADDLE WIDTH IS 52"
 SERVICE RANGE IS 3" TO 20"
 FORKS ARE ADJUSTABLE FROM 8" TO 36"
 FORKS ARE 1 1/2" THICK X 4" WIDE X 48" LONG
 OVERALL LENGTH IS 94 7/16"
 OVERALL HEIGHT IS 47"
 18" FOAM FILLED FRONT WHEELS
 SAFETY HANDLE WITH FORWARD/NEUTRAL/REVERSE
 190CC BRIGGS AND STRATTON ENGINE
 ±8° POWER TILT FOR FORKS
 HAND LEVERS TO CONTROL LIFT/LOWER/TILT
 DURABLE LIQUID PAINT BLUE FINISH

A P P R O V A L

I, THE UNDERSIGNED, AGREE THAT THE PRODUCT AS REPRESENTED SATISFIES DESIGN AND DIMENSION REQUIREMENTS. I ALSO ACKNOWLEDGE MY DUTY TO CONFIRM PRODUCT AND INSTALLATION COMPLIANCE WITH ALL APPLICABLE FEDERAL, STATE AND LOCAL REGULATIONS AND STANDARDS.
UNITS REQUIRING APPROVAL DRAWINGS OR MODIFIED ARE NON-RETURNABLE
 As drawn As marked

Signed: _____ Date: _____
 Printed Name: _____

LEAD TIME WILL START UPON RECEIPT OF SIGNED APPROVAL DRAWING

| | | |
|-----------------------------|-------------|------------|
| DISTRIBUTOR'S NAME: | | P.O.# |
| VESTIL MANUFACTURING | | X |
| DRAWN BY: KGH | | W.O.# |
| DATE: 6/26/2018 | | X |
| REFERENCE: X | SCALE: 1:22 | SALES: X |
| QUOTED LEAD TIME: X | QUOTE # | FILE NAME: |
| | X | 50-007-025 |