

ALUMINUM WHEEL RISER - ATWR-24-10-66

APPROX WEIGHT: 106.68 lbs.
DOES NOT INCLUDE WEIGHT OF POWER OR PACKAGING!!!

*** ANY ADDITIONS, DELETIONS, OR OMISSIONS MUST BE CORRECTED ON THIS DRAWING AS THIS DRAWING WILL BE CONSIDERED ALL INCLUSIVE ***

ALL GRAPHICS PROVIDED ARE FOR REFERENCE ONLY. IF CERTAIN DIMENSIONS ARE CRITICAL PLEASE VERIFY THOSE DIMENSIONS WITH YOUR SALESPERSON

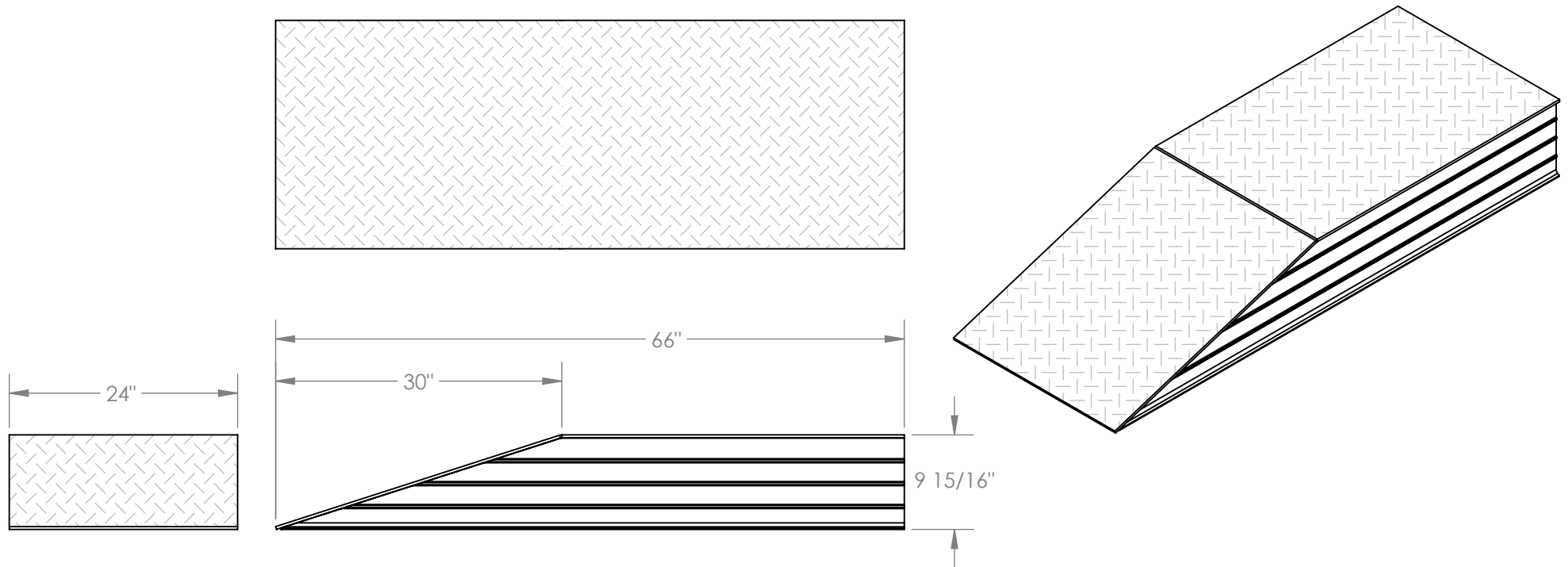

DIMENSION TOLERANCE $\pm 1/4"$

STANDARD FEATURES

- MODEL NUMBER IS ATWR-24-10-66
- OVERALL WIDTH IS 24"
- OVERALL LENGTH IS 66"
- OVERALL HEIGHT IS 9 15/16"
- ANGLED APPROACH LENGTH IS 30"
- MAX UNIFORM CAPACITY IS 30,000 LBS PER PAIR (SOLD EACH)
- ALL WELDED ALUMINUM CONSTRUCTION
- HEAVY DUTY ALUMINUM TREAD PLATE TOP SURFACES

SPECIAL FEATURES

NONE

| | | |
|---|--|--|
| APPROVAL | I, THE UNDERSIGNED, AGREE THAT THE PRODUCT AS REPRESENTED SATISFIES DESIGN AND DIMENSION REQUIREMENTS. I ALSO ACKNOWLEDGE MY DUTY TO CONFIRM PRODUCT AND INSTALLATION COMPLIANCE WITH ALL APPLICABLE FEDERAL, STATE AND LOCAL REGULATIONS AND STANDARDS. | |
| | ANY MODIFIED UNITS ARE NON-RETURNABLE | |
| | [] As drawn [] As marked | |
| | Signed: _____ Date: _____ | |
| Printed Name: _____ | | |
| <i>LEAD TIME WILL START UPON RECEIPT OF SIGNED APPROVAL DRAWING</i> | | |

| | |
|---|--|
| FOR INTERNAL USE ONLY PROJECT SIGN OFF | |
| SALES | |
| ENG. | |
| FAB. | |
| POWER | |

| | | |
|-----------------------------|---------|------------|
| DISTRIBUTOR'S NAME: | | P.O.# |
| VESTIL MANUFACTURING | | X |
| DRAWN BY: | DATE: | W.O.# |
| MTS | 9/24/13 | X |
| REFERENCE: | SCALE: | SALES: |
| X | 1:16 | X |
| QUOTED LEAD TIME: | QUOTE # | FILE NAME: |
| X | X | 18-007-167 |