

INTERNESTABLE RACK BASE - BASE-4848

APPROX WEIGHT: 116.48 lbs.
 DOES NOT INCLUDE WEIGHT OF POWER OR PACKAGING!!!

*** ANY ADDITIONS, DELETIONS, OR OMISSIONS MUST BE CORRECTED ON THIS DRAWING AS THIS DRAWING WILL BE CONSIDERED ALL INCLUSIVE ***
 ALL GRAPHICS PROVIDED ARE FOR REFERENCE ONLY. IF CERTAIN DIMENSIONS ARE CRITICAL PLEASE VERIFY THOSE DIMENSIONS WITH YOUR SALESPERSON

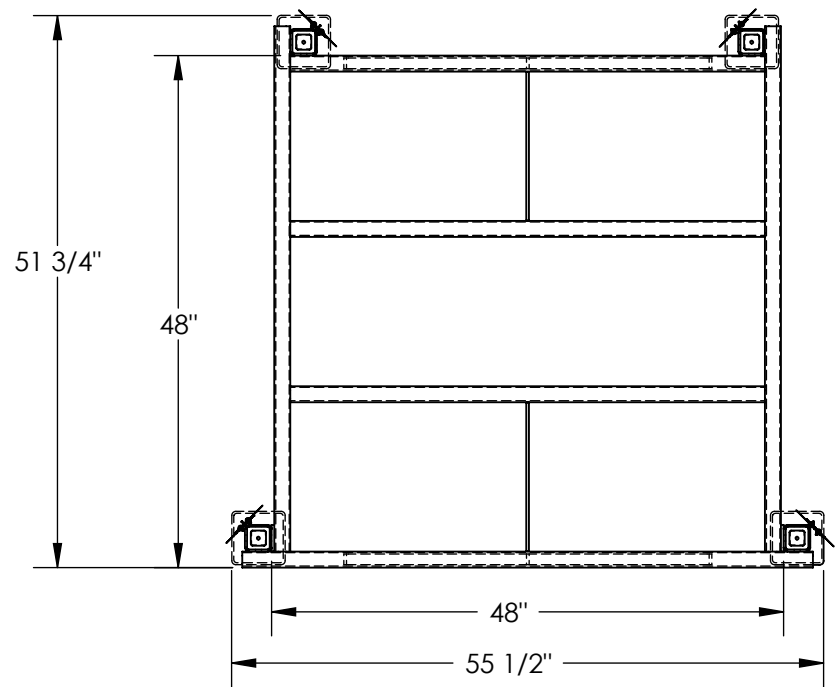

SELF LOCKING QUICK
 RELEASE PINS & LANYARD

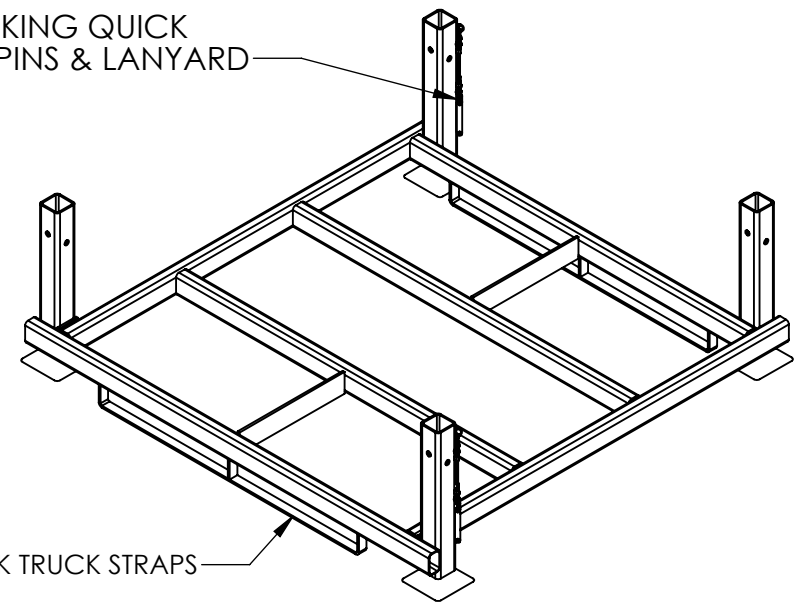

FORK TRUCK STRAPS

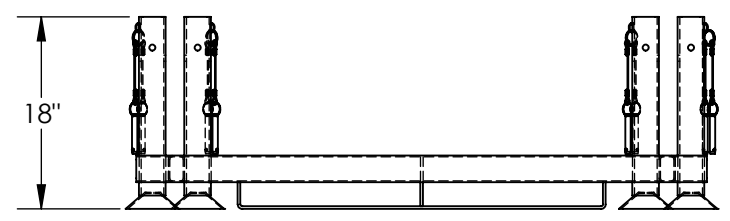

STANDARD FEATURES

- MODEL NUMBER IS BASE-4848
- OVERALL WIDTH: 55 1/2"
- USABLE WIDTH: 48"
- OVERALL LENGTH: 51 3/4"
- USABLE LENGTH: 48"
- OVERALL HEIGHT: 18"
- MAX LOADING CAPACITY: 4,000 lbs.
- DOUBLE LOCKING PINS ON ALL 4 CORNERS (INCLUDED)
- TOUGH BAKED IN POWDER COATED ERGO BLUE FINISH

SPECIAL FEATURES

NONE

DIMENSION TOLERANCE ± 1/4"

I, THE UNDERSIGNED, AGREE THAT THE PRODUCT AS REPRESENTED SATISFIES DESIGN AND DIMENSION REQUIREMENTS. I ALSO ACKNOWLEDGE MY DUTY TO CONFIRM PRODUCT AND INSTALLATION COMPLIANCE WITH ALL APPLICABLE FEDERAL, STATE AND LOCAL REGULATIONS AND STANDARDS.

UNITS REQUIRING APPROVAL DRAWINGS OR MODIFIED ARE NON-RETURNABLE

[] As drawn [] As marked

Signed: _____ Date: _____

Printed Name: _____

LEAD TIME WILL START UPON RECEIPT OF SIGNED APPROVAL DRAWING

DISTRIBUTOR'S NAME:		P.O.#
VESTIL MANUFACTURING		X
DRAWN BY: J.R.		W.O.#
DATE: 2/10/10		X
REFERENCE: X	SCALE: 1:18	SALES: X
QUOTED LEAD TIME: X	QUOTE #	FILE NAME:
	X	31-007-114