

ALUMINUM HYDRAULIC ELEVATING CART, CART-200-ALUM

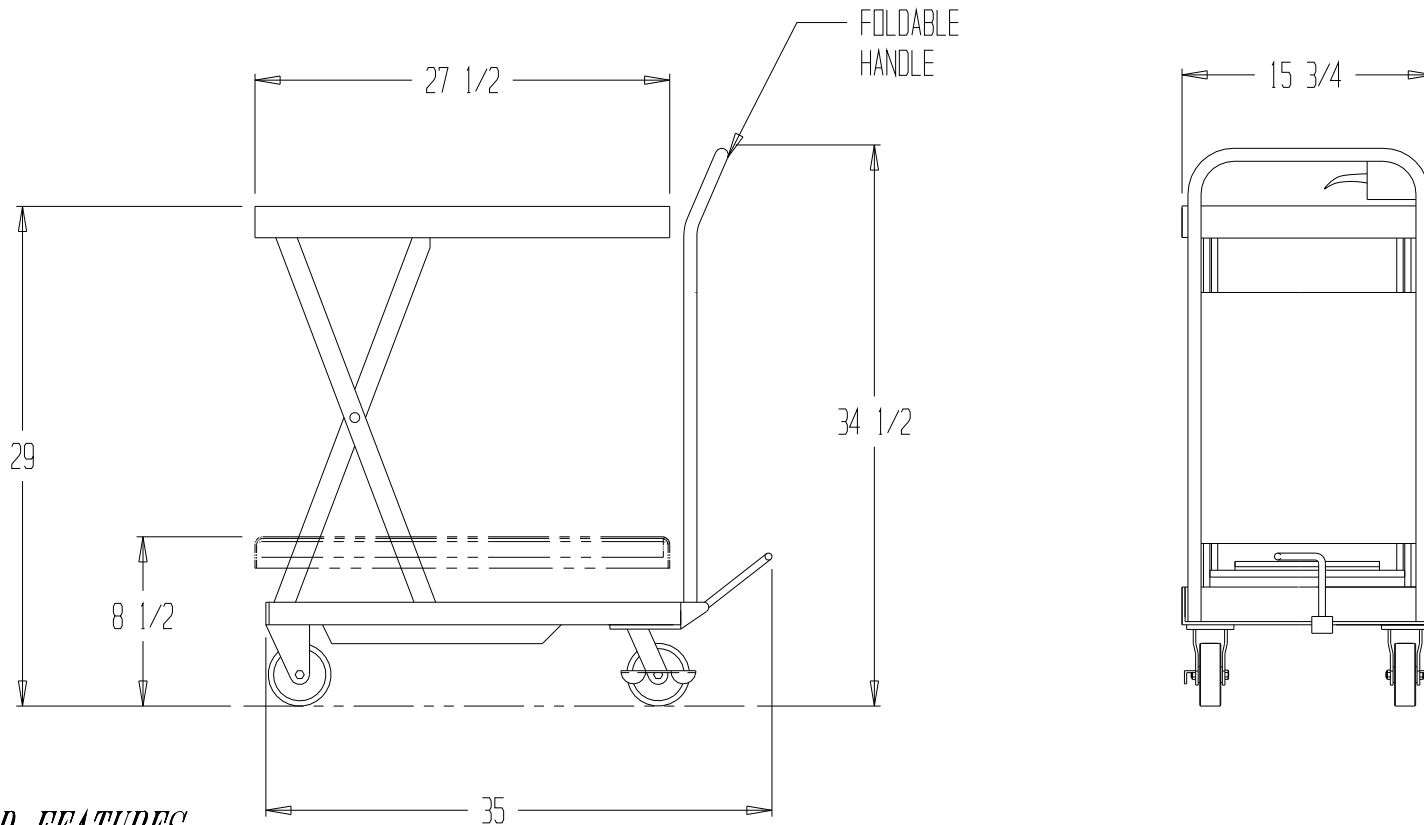

STANDARD FEATURES

MODEL NUMBER: CART-200-ALUM
 CAPACITY: 220 LBS.
 PLATFORM: 15 3/4" x 27 1/2"
 PLATFORM RAISED HEIGHT: 29"
 PLATFORM LOWERED HEIGHT: 8 1/2"
 STANDARD SINGLE SPEED FOOT PUMP
 4 X 1 1/4 POLY ON POLY CASTERS:
 TWO SWIVEL W/BRAKE, TWO RIGID

SPECIAL FEATURES

NONE

DECK TOLERANCES ARE +/- 1/2"
 TABLE HEIGHT TOLERANCES ARE +/- 1/2"

All graphics provided are for reference only.
 If certain dimensions are critical please
 verify those dimensions with your salesperson

Any additions, deletions or
 omissions must be corrected
 on this drawing, as this drawing
 will be considered all inclusive.

A I, THE UNDERSIGNED, AGREE THAT THE PRODUCT AS REPRESENTED
P SATISFIES DESIGN & DIMENSION REQUIREMENTS. I ALSO ACKNOWLEDGE
P MY DUTY TO CONFIRM PRODUCT & INSTALLATION COMPLIANCE WITH ALL
R APPLICABLE FEDERAL, STATE AND LOCAL REGULATIONS & STANDARDS.
O **ALL SPECIAL UNITS ARE NON-RETURNABLE**
V [] As drawn [] As marked
A Signed: _____ Date: _____
L LEAD TIME WILL START UPON RECEIPT OF SIGNED APPROVAL DRAWING

DISTRIBUTOR'S NAME:		P.O.#: _
VESTIL MANUFACTURING		W.O.#: _
DRAWN BY: SR	DATE: 10-29-10	SALES: _
REFERENCE:		DRWG./FILE NAME:
-		CART-200-ALUM
SCALE: NTS		