

# DOUBLE SCISSOR LIFT TABLE - EHLTD-4864-2-84

APPROX WEIGHT: 1632.18 lbs.  
 DOES NOT INCLUDE WEIGHT OF POWER OR PACKAGING!!!

\*\*\* ANY ADDITIONS, DELETIONS, OR OMISSIONS MUST BE CORRECTED ON THIS DRAWING AS THIS DRAWING WILL BE CONSIDERED ALL INCLUSIVE \*\*\*

ALL GRAPHICS PROVIDED ARE FOR REFERENCE ONLY. IF CERTAIN DIMENSIONS ARE CRITICAL PLEASE VERIFY THOSE DIMENSIONS WITH YOUR SALESPERSON

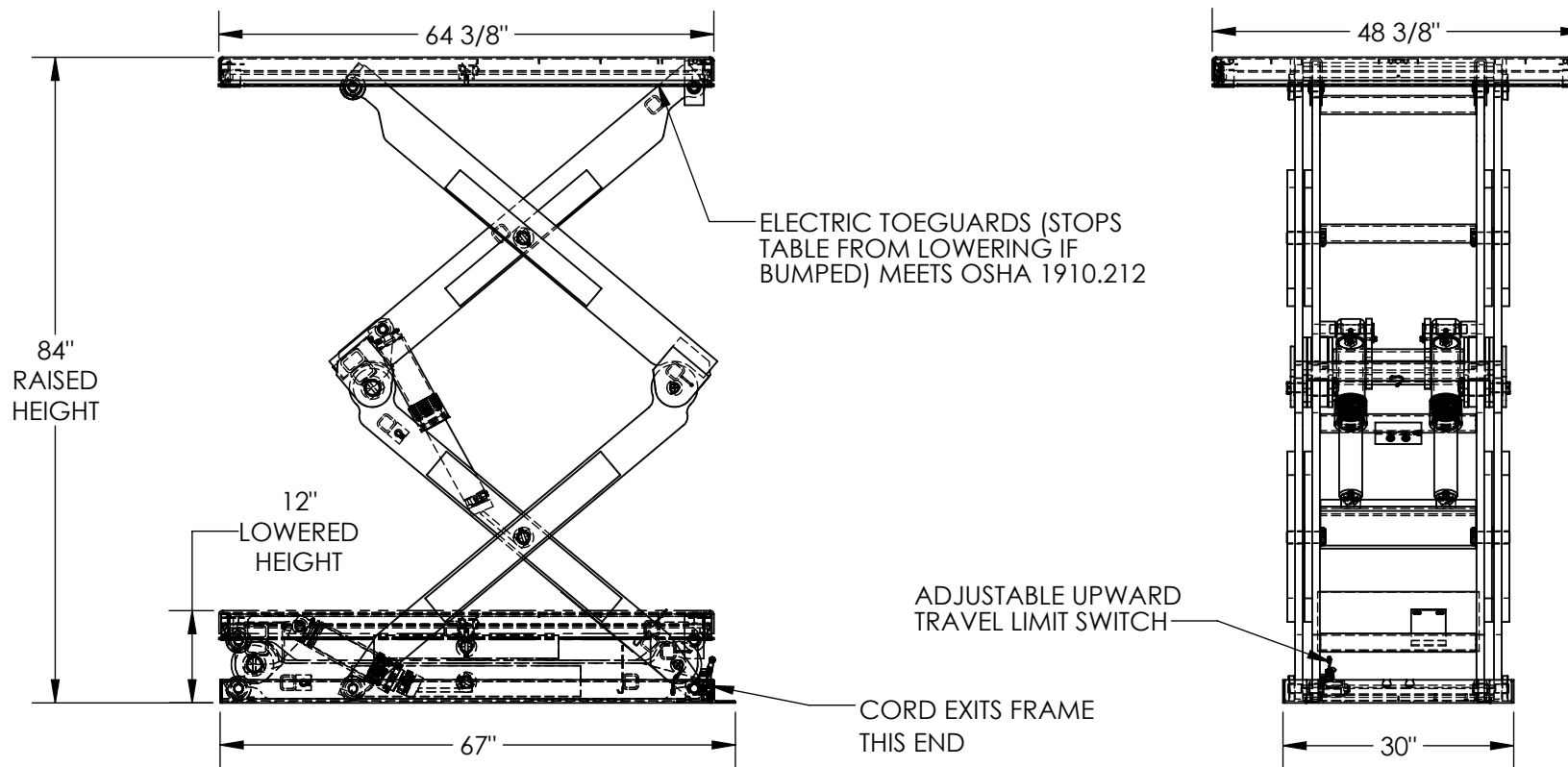

DIMENSION TOLERANCE ± 1/4"

DECK TOLERANCE ± 1/2"  
 TABLE HEIGHT TOLERANCE ± 1/2"  
 DECK FLATNESS ± 1/4"

## STANDARD FEATURES

- MODEL NUMBER IS EHLTD-4864-2-84
- PLATFORM WIDTH: 48 3/8"
- PLATFORM LENGTH: 64 3/8"
- PLATFORM RAISED HEIGHT: 84"
- PLATFORM LOWERED HEIGHT: 12"
- CAPACITY (EVENLY DISTRIBUTED): 2,000 LBS
- INTERNAL POWER UNIT
- 24V WATER RESISTANT,
- CONTROL IS HANDHELD, 2 BUTTON, NEMA 4
- PENDANT WITH MINIMUM 8' USABLE COIL CORD
- 56 FRAME, 2 HP MOTOR (@ 3 PHASE)
- EMERGENCY BRASS SAFETY VELOCITY FUSE IN CYLINDERS
- UPPER TRAVEL LIMIT SWITCH
- ELECTRIC PINCH POINT GUARD
- DURABLE LIQUID PAINT BLUE FINISH

## SPECIAL FEATURES

NONE

## PLEASE CIRCLE SPECIFICATIONS:

POWER	AC	<del>DC (12V)</del>	<del>AIR/OIL</del>
MOTOR VOLTAGE	<del>115</del>	<del>208</del>	<del>230</del> 460
DEDICATED CIRCUIT REQUIRED 60Hz			
MOTOR PHASE	<del>SINGLE</del>	THREE	
CONTROL	HAND	<del>FOOT</del>	

APPROVAL

I, THE UNDERSIGNED, AGREE THAT THE PRODUCT AS REPRESENTED SATISFIES DESIGN AND DIMENSION REQUIREMENTS. I ALSO ACKNOWLEDGE MY DUTY TO CONFIRM PRODUCT AND INSTALLATION COMPLIANCE WITH ALL APPLICABLE FEDERAL, STATE AND LOCAL REGULATIONS AND STANDARDS.

**UNITS REQUIRING APPROVAL DRAWINGS OR MODIFIED ARE NON-RETURNABLE**

[ ] As drawn [ ] As marked

Signed: \_\_\_\_\_ Date: \_\_\_\_\_

Printed Name: \_\_\_\_\_

LEAD TIME WILL START UPON RECEIPT OF SIGNED APPROVAL DRAWING

DISTRIBUTOR'S NAME:		P.O.#
VESTIL MANUFACTURING		X
DRAWN BY: KEC		W.O.#
DATE: 10/4/16		X
REFERENCE: X	SCALE: 1:24	SALES: X
QUOTED LEAD TIME: X	QUOTE #	FILE NAME:
	X	26-007-071-002