

# LIFT AND TILT SCISSOR TABLE - EHLTT-3648-1-47

APPROX WEIGHT: 1005 lbs.  
DOES NOT INCLUDE WEIGHT OF POWER OR PACKAGING!!!

\*\*\* ANY ADDITIONS, DELETIONS, OR OMISSIONS MUST BE CORRECTED ON THIS DRAWING AS THIS DRAWING WILL BE CONSIDERED ALL INCLUSIVE \*\*\*

ALL GRAPHICS PROVIDED ARE FOR REFERENCE ONLY. IF CERTAIN DIMENSIONS ARE CRITICAL PLEASE VERIFY THOSE DIMENSIONS WITH YOUR SALESPERSON

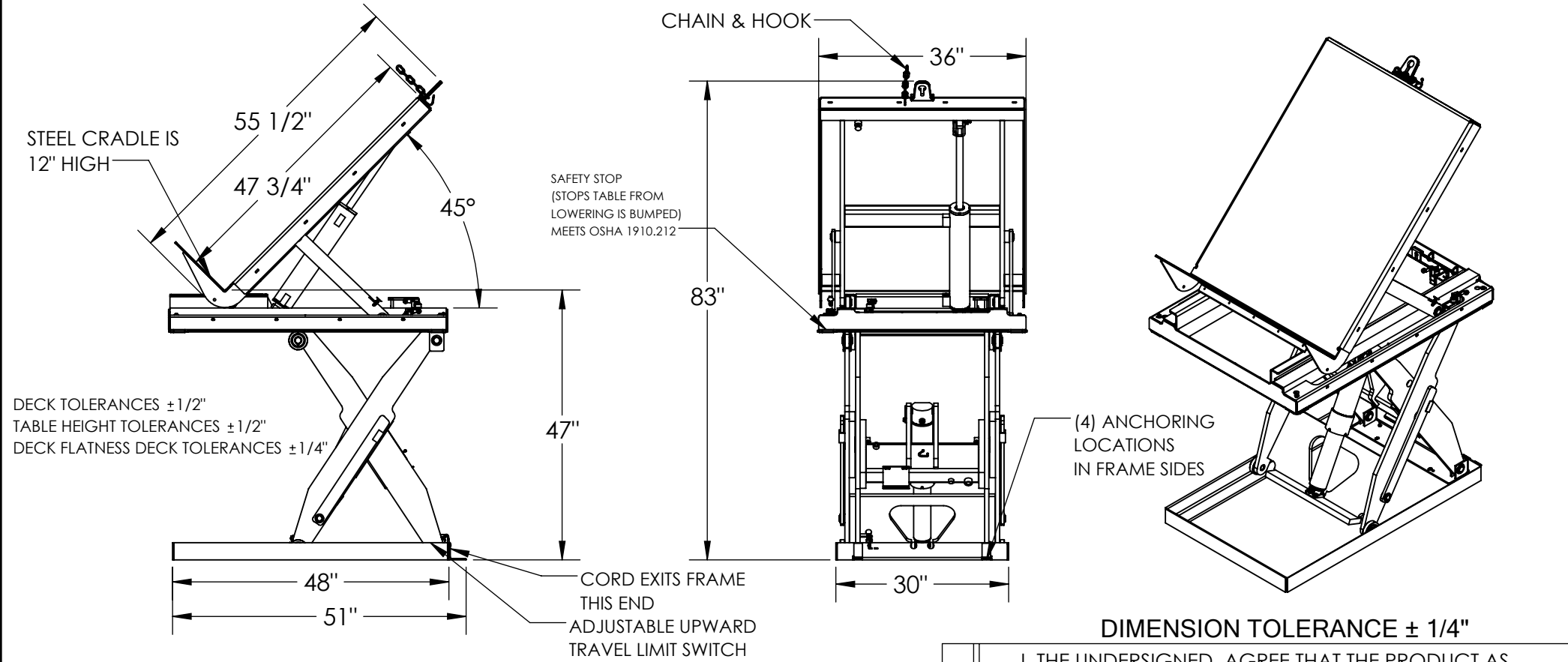

DIMENSION TOLERANCE ± 1/4"

## STANDARD FEATURES

- MODEL NUMBER: EHLTT-3648-1-47
- MAX. CAPACITY: 1,000 LBS
- FRAME WIDTH: 30"
- OVERALL LENGTH: 55 1/2"
- PLATFORM WIDTH: 36"
- PLATFORM LENGTH: 47 3/4"
- PLATFORM RAISED HEIGHT: 47"
- PLATFORM LOWERED HEIGHT: 11"
- OVERALL HEIGHT: 83"
- PLATFORM TILTS ON THE END OF THE LEG ASSEMBLY
- PLATFORM TILTING STYLE IS A SLIDE TILT
- Ø 1/4" X 60" CHAIN AND HOOK (NOT DRAWN TO SCALE)
- MAXIMUM TILT ANGLE IS 45°
- INTERNAL POWER UNIT
- CONTROL IS HANDHELD, 4 BUTTON, NEMA 4
- PENDANT WITH MINIMUM 8' USABLE COIL CORD
- DURABLE LIQUID PAINT BLUE FINISH

## PLEASE CIRCLE SPECIFICATIONS:

POWER	AC	<del>DC (12V)</del>	<del>AIR/OIL</del>
MOTOR VOLTAGE	<del>115</del>	<del>200</del>	<del>200</del> 460
DEDICATED CIRCUIT REQUIRED 60Hz			
MOTOR PHASE	<del>SINGLE</del>	THREE	
CONTROL	HAND	<del>FOOT</del>	

## SPECIAL FEATURES

NONE

**APPROVAL**

I, THE UNDERSIGNED, AGREE THAT THE PRODUCT AS REPRESENTED SATISFIES DESIGN AND DIMENSION REQUIREMENTS. I ALSO ACKNOWLEDGE MY DUTY TO CONFIRM PRODUCT AND INSTALLATION COMPLIANCE WITH ALL APPLICABLE FEDERAL, STATE AND LOCAL REGULATIONS AND STANDARDS.

**UNITS REQUIRING APPROVAL DRAWINGS OR MODIFIED ARE NON-RETURNABLE**

[ ] As drawn [ ] As marked

Signed: \_\_\_\_\_ Date: \_\_\_\_\_

Printed Name: \_\_\_\_\_

LEAD TIME WILL START UPON RECEIPT OF SIGNED APPROVAL DRAWING

DISTRIBUTOR'S NAME:		P.O.#
VESTIL MANUFACTURING		-
DRAWN BY: CRA		W.O.#
DATE: 07/22/2021		-
REFERENCE:	SCALE: 1:25	SALES: -
-	-	FILE NAME:
QUOTED LEAD TIME: -	QUOTE # -	02-007-333