

# ELECTRIC POWERED ROLL PALLET TRUCK - EPT-4548-45-RL

APPROX WEIGHT: 1180 lbs.  
DOES NOT INCLUDE WEIGHT OF POWER OR PACKAGING!!!

\*\*\* ANY ADDITIONS, DELETIONS, OR OMISSIONS MUST BE CORRECTED ON THIS DRAWING AS THIS DRAWING WILL BE CONSIDERED ALL INCLUSIVE \*\*\*

ALL GRAPHICS PROVIDED ARE FOR REFERENCE ONLY. IF CERTAIN DIMENSIONS ARE CRITICAL PLEASE VERIFY THOSE DIMENSIONS WITH YOUR SALESPERSON

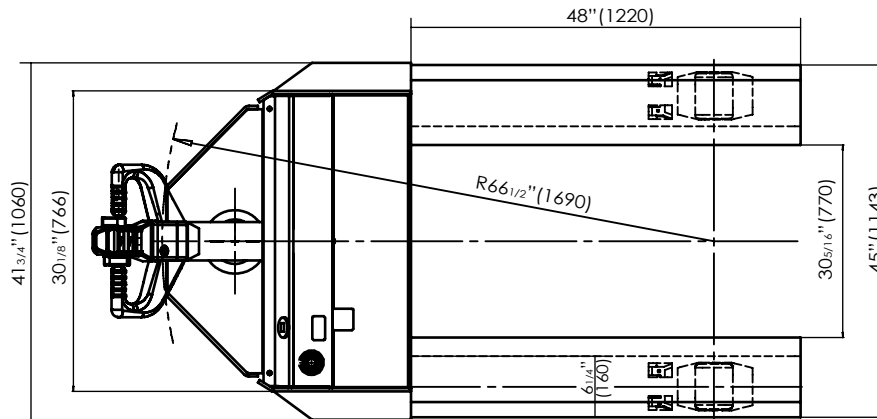
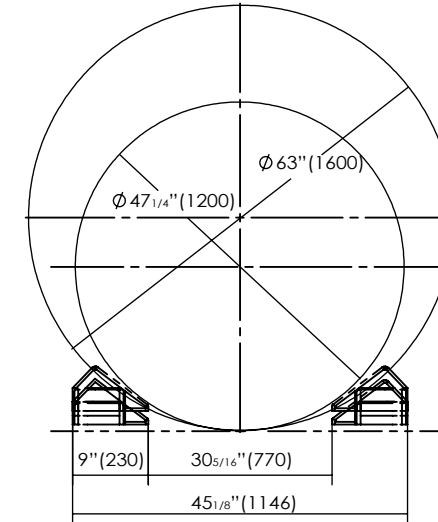
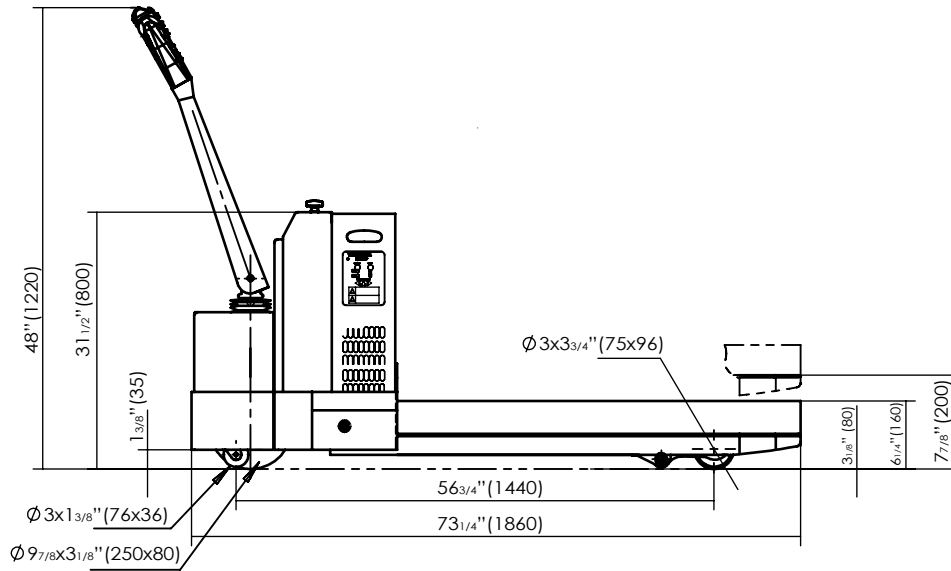

DIMENSION TOLERANCE ± 1/2"

APPROVAL

I, THE UNDERSIGNED, AGREE THAT THE PRODUCT AS REPRESENTED SATISFIES DESIGN AND DIMENSION REQUIREMENTS. I ALSO ACKNOWLEDGE MY DUTY TO CONFIRM PRODUCT AND INSTALLATION COMPLIANCE WITH ALL APPLICABLE FEDERAL, STATE AND LOCAL REGULATIONS AND STANDARDS.  
**UNITS REQUIRING APPROVAL DRAWINGS OR MODIFIED ARE NON-RETURNABLE**

[ ] As drawn [ ] As marked

Signed: \_\_\_\_\_ Date: \_\_\_\_\_

Printed Name: \_\_\_\_\_

LEAD TIME WILL START UPON RECEIPT OF SIGNED APPROVAL DRAWING

## STANDARD FEATURES

- MODEL NUMBER IS: EPT-4548-45-RL
- MAX UNIFORM CAPACITY IS: 4,500 Lbs
- OVERALL FORK WIDTH IS: 45"
- OVERALL FORK LENGTH IS: 48"
- HANDLES ROLL SIZES OF: Ø47 1/4" TO Ø63"
- RAISED FORK HEIGHT IS: 7 7/8"
- 1.2 KW DRIVE MOTOR & 2.0 KW LIFT MOTOR
- (4) 6V, 200Ah DEEP CYCLE BATTERIES
- TOUGH BAKED IN POWDER COATED BLACK AND YELLOW FINISH

## SPECIAL FEATURES

NONE

DISTRIBUTOR'S NAME:		P.O.#
VESTIL MANUFACTURING		X
DRAWN BY: TM	DATE: 6/25/2021	W.O.#
REFERENCE: X	SCALE: NTS	X
QUOTED LEAD TIME: X	QUOTE #	FILE NAME:
	X	EPT-4548-45-RL