

DUAL RATCHET STRAP - FDRS-V2

APPROX WEIGHT: 13.40 lbs.
 DOES NOT INCLUDE WEIGHT OF POWER OR PACKAGING!!!

*** ANY ADDITIONS, DELETIONS, OR OMISSIONS MUST BE CORRECTED ON THIS DRAWING AS THIS DRAWING WILL BE CONSIDERED ALL INCLUSIVE ***
 ALL GRAPHICS PROVIDED ARE FOR REFERENCE ONLY. IF CERTAIN DIMENSIONS ARE CRITICAL PLEASE VERIFY THOSE DIMENSIONS WITH YOUR SALESPERSON

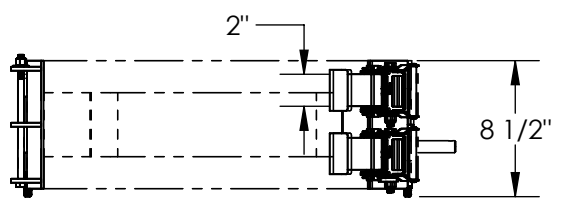
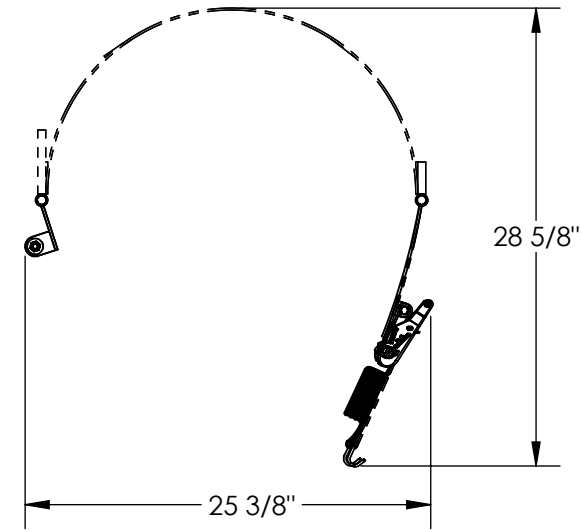

NUT AND 8" LONG BOLT ARE REMOVED FROM THE STANDARD DRUM SADDLE ASSEMBLY. THE STANDARD SWINGING DOORS ARE REMOVED AND REPLACED WITH THE FDRS SWINGING DOORS (WITH STRAPS)

STRAPS HOOK ONTO BOLTS ON OPPOSITE SIDE

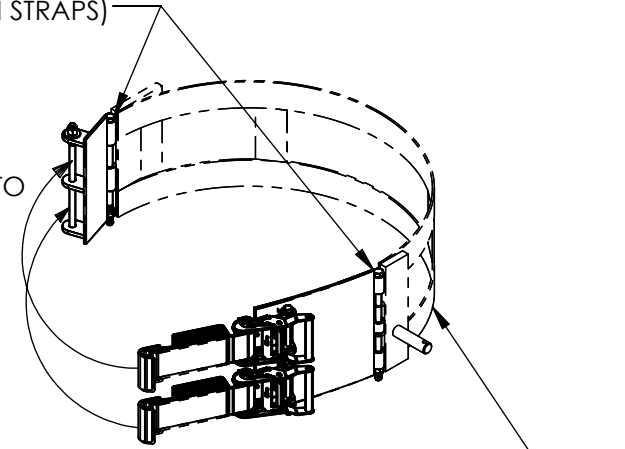

3-D VIEW FOR REFERENCE

DRUM SADDLE ASSEMBLY FROM THE DRUM HANDLING UNIT IS SHOWN FOR REFERENCE. NOT INCLUDED IN FDRS.

DIMENSION TOLERANCE ± 1/4"

STANDARD FEATURES

- MODEL NUMBER IS FDRS-V2
- THE FDRS-V2 MAY BE INSTALLED ON THE FOLLOWING DRUM HANDLING MODELS: DCR-110-55, DCR-205-8, DCR-205-15
- MAX CAPACITY IS DETERMINED BY THE MODEL THE FDRS IS USED ON
- OVERALL WIDTH IS 25 3/8"
- OVERALL LENGTH IS 28 5/8"
- OVERALL HEIGHT IS 8 1/2"
- (2) RATCHET STRAPS FOR DRUM RETENTION
- STRAP WIDTH IS 2"
- STRAP LENGTH IS 36"
- STRAP COLOR IS ORANGE

SPECIAL FEATURES

NONE

APPROVAL	I, THE UNDERSIGNED, AGREE THAT THE PRODUCT AS REPRESENTED SATISFIES DESIGN AND DIMENSION REQUIREMENTS. I ALSO ACKNOWLEDGE MY DUTY TO CONFIRM PRODUCT AND INSTALLATION COMPLIANCE WITH ALL APPLICABLE FEDERAL, STATE AND LOCAL REGULATIONS AND STANDARDS.	
	ANY MODIFIED UNITS ARE NON-RETURNABLE	
	[] As drawn	[] As marked
Signed: _____		Date: _____
Printed Name: _____		
LEAD TIME WILL START UPON RECEIPT OF SIGNED APPROVAL DRAWING		

FOR INTERNAL USE ONLY PROJECT SIGN OFF	
SALES	
ENG.	
FAB.	
POWER	

DISTRIBUTOR'S NAME:		P.O.#
VESTIL MANUFACTURING		X
DRAWN BY: MTS		W.O.#
DATE: 12/16/2018		X
REFERENCE: X	SCALE: 1:12	SALES: X
QUOTED LEAD TIME: X	QUOTE #	FILE NAME:
	X	09-007-213