

LEVELING FIXED HEIGHT ALUMINUM GANTRY - FHA-4-8-10-ALO

APPROX WEIGHT: 260.07 lbs.
DOES NOT INCLUDE WEIGHT OF POWER OR PACKAGING!!!

*** ANY ADDITIONS, DELETIONS, OR OMISSIONS MUST BE CORRECTED ON THIS DRAWING AS THIS DRAWING WILL BE CONSIDERED ALL INCLUSIVE ***
ALL GRAPHICS PROVIDED ARE FOR REFERENCE ONLY. IF CERTAIN DIMENSIONS ARE CRITICAL PLEASE VERIFY THOSE DIMENSIONS WITH YOUR SALESPERSON

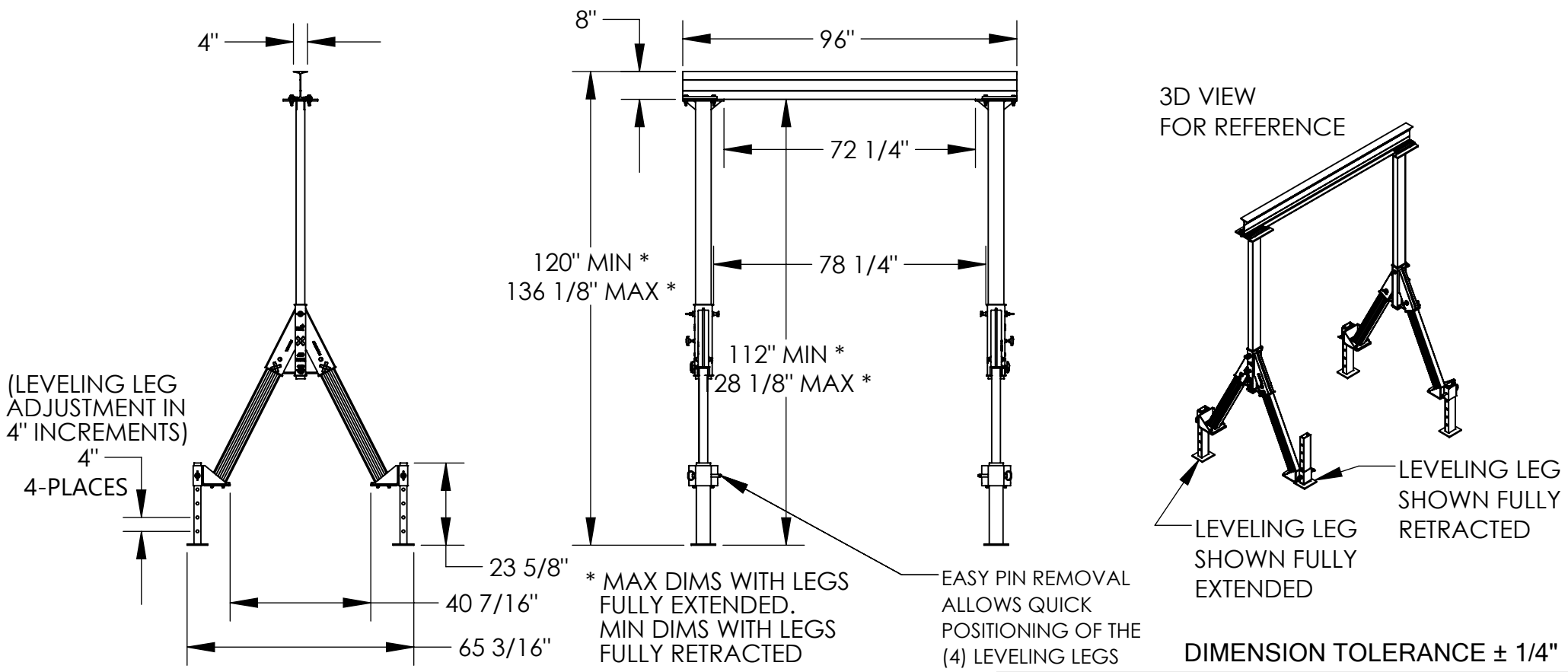

STANDARD FEATURES

MODEL NUMBER IS FHA-4-8-10-ALO
CAPACITY IS 4,000 LBS.
BASE WIDTH IS 65 3/16"
OVERALL HEIGHT IS 136" MAX *
I-BEAM SIZE IS 8" TALL WITH 4" FLANGE WIDTH
OVERALL I-BEAM LENGTH IS 96"
USABLE I-BEAM LENGTH IS 72 1/4"
LEVELING LEG HEIGHT IS INDIVIDUALLY ADJUSTED UP TO 16" MAX. TO LEVEL CRANE
UNDER I-BEAM HEIGHT IS 112" MIN TO 128" MAX *
CRANE MAY BE TAKEN APART AND BUNDLED WITH (2) INCLUDED STRAPS FOR EASY TRANSPORT ALUMINUM CONSTRUCTION

SPECIAL FEATURES

NONE

APPROVAL

I, THE UNDERSIGNED, AGREE THAT THE PRODUCT AS REPRESENTED SATISFIES DESIGN AND DIMENSION REQUIREMENTS. I ALSO ACKNOWLEDGE MY DUTY TO CONFIRM PRODUCT AND INSTALLATION COMPLIANCE WITH ALL APPLICABLE FEDERAL, STATE AND LOCAL REGULATIONS AND STANDARDS.
UNITS REQUIRING APPROVAL DRAWINGS OR MODIFIED ARE NON-RETURNABLE
[] As drawn [] As marked

Signed: _____ Date: _____
Printed Name: _____

LEAD TIME WILL START UPON RECEIPT OF SIGNED APPROVAL DRAWING

DISTRIBUTOR'S NAME:		P.O.#
VESTIL MANUFACTURING		X
DRAWN BY: MTS		W.O.#
DATE: 10/11/2019		X
REFERENCE: X	SCALE: 1:42	SALES: X
QUOTED LEAD TIME: X	QUOTE # X	FILE NAME:
		28-007-446