

# FIXED STEEL GANTRY CRANE - KNOCKDOWN - FHSN-10-10

APPROX WEIGHT: 887.36 lbs.  
 DOES NOT INCLUDE WEIGHT OF POWER OR PACKAGING!!!

\*\*\* ANY ADDITIONS, DELETIONS, OR OMISSIONS MUST BE CORRECTED ON THIS DRAWING AS THIS DRAWING WILL BE CONSIDERED ALL INCLUSIVE \*\*\*  
 ALL GRAPHICS PROVIDED ARE FOR REFERENCE ONLY. IF CERTAIN DIMENSIONS ARE CRITICAL PLEASE VERIFY THOSE DIMENSIONS WITH YOUR SALESPERSON

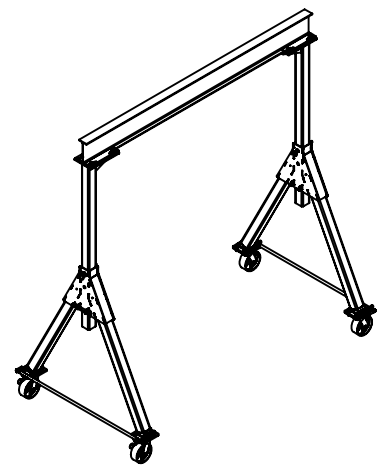
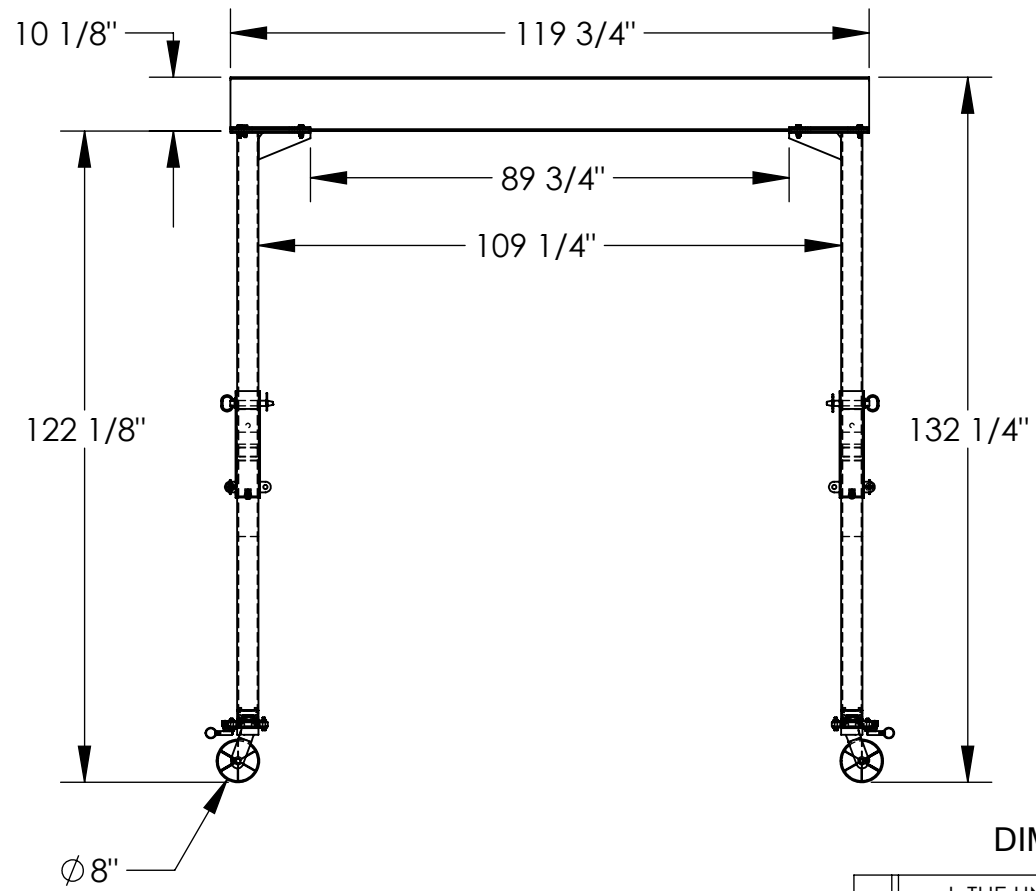
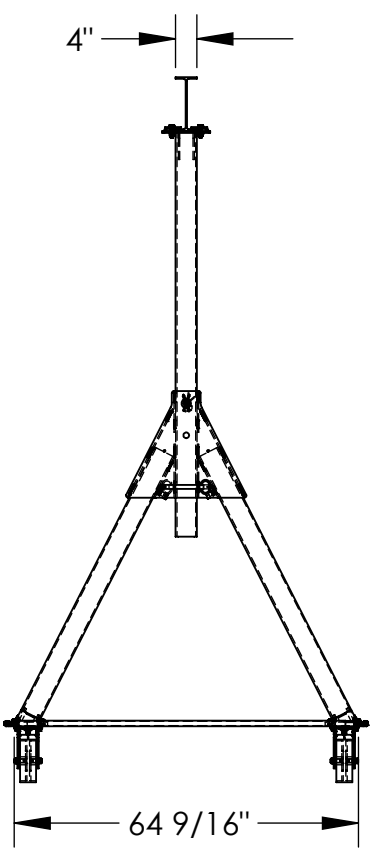

3D VIEW FOR REFERENCE ONLY

DIMENSION TOLERANCE ± 1/4"

## STANDARD FEATURES

- MODEL NUMBER IS FHSN-10-10
- CAPACITY IS 10,000 LBS.
- BASE WIDTH IS 64 9/16"
- OVERALL HEIGHT IS 132 1/4"
- I-BEAM HEIGHT IS 10 1/8"
- I-BEAM FLANGE WIDTH IS 4"
- OVERALL I-BEAM LENGTH IS 119 3/4"
- USABLE I-BEAM LENGTH IS 89 3/4"
- UNDER I-BEAM HEIGHT IS 122 1/8"
- CASTERS: (4) Ø8" X 3" WIDE STEEL SWIVEL CASTERS WITH FOUR LOCKING POSITIONS

## SPECIAL FEATURES

NONE

**APPROVAL**

I, THE UNDERSIGNED, AGREE THAT THE PRODUCT AS REPRESENTED SATISFIES DESIGN AND DIMENSION REQUIREMENTS. I ALSO ACKNOWLEDGE MY DUTY TO CONFIRM PRODUCT AND INSTALLATION COMPLIANCE WITH ALL APPLICABLE FEDERAL, STATE AND LOCAL REGULATIONS AND STANDARDS.  
**UNITS REQUIRING APPROVAL DRAWINGS OR MODIFIED ARE NON-RETURNABLE**  
 As drawn     As marked

Signed: \_\_\_\_\_ Date: \_\_\_\_\_  
 Printed Name: \_\_\_\_\_

**LEAD TIME WILL START UPON RECEIPT OF SIGNED APPROVAL DRAWING**

DISTRIBUTOR'S NAME:		P.O.#
VESTIL MANUFACTURING		X
DRAWN BY: MTS		DATE: 02/27/15
REFERENCE: X		SCALE: 1:36
QUOTED LEAD TIME: X	QUOTE #	FILE NAME:
	X	28-007-389