

GANTRY POWER TRACTION DRIVE - GPTD-2

APPROX WEIGHT: 257 lbs.
 DOES NOT INCLUDE WEIGHT OF POWER OR PACKAGING!!!

*** ANY ADDITIONS, DELETIONS, OR OMISSIONS MUST BE CORRECTED ON THIS DRAWING AS THIS DRAWING WILL BE CONSIDERED ALL INCLUSIVE ***
 ALL GRAPHICS PROVIDED ARE FOR REFERENCE ONLY. IF CERTAIN DIMENSIONS ARE CRITICAL PLEASE VERIFY THOSE DIMENSIONS WITH YOUR SALESPERSON

ADJUSTABLE HEIGHT GANTRY CRANE
 SHOWN FOR REFERENCE ONLY.
 SOLD SEPERATLY

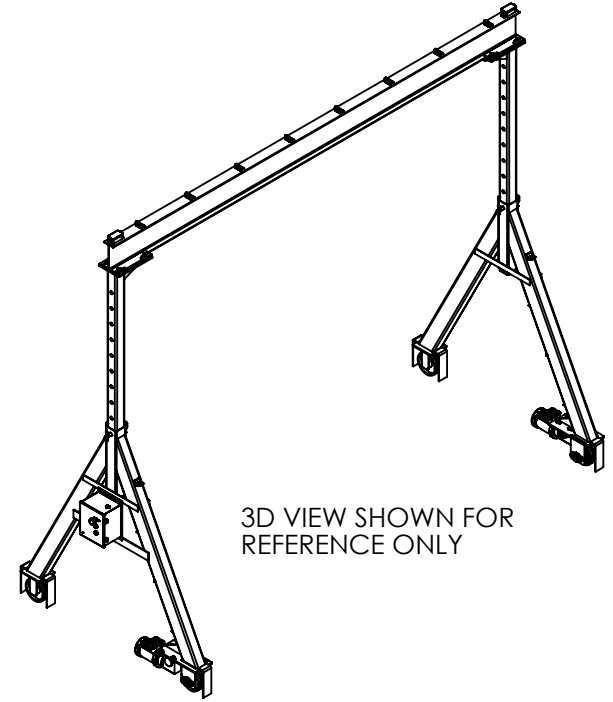
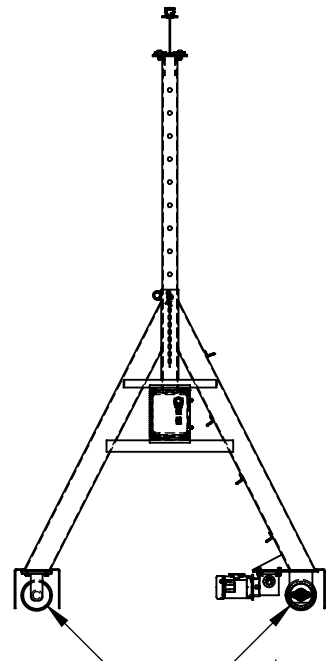
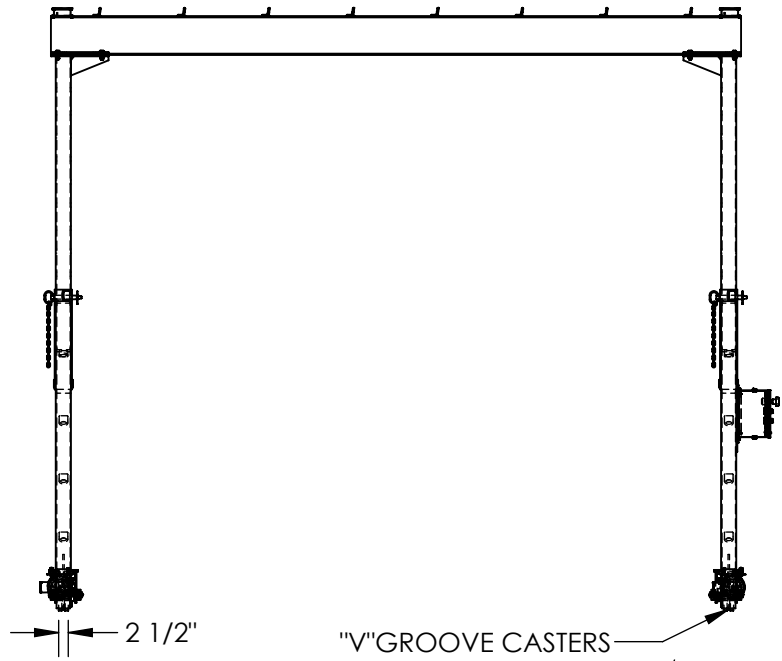

3D VIEW SHOWN FOR REFERENCE ONLY

"V" GROOVE CASTERS
 Ø8" NON-POWERED CASTERS
 Ø8" POWERED CASTERS

DIMENSION TOLERANCE ± 1/4"

STANDARD FEATURES

- MODEL NUMBER IS GPTD-2
- MAX CAPACITY IS 4000 LB
- WHEEL DIAMETER IS 8"
- WHEEL WIDTH IS 2 1/2"
- (4) CAST IRON "V" GROOVE CASTERS
- (2) CASTERS POWERED BY ELECTRIC MOTOR WITH REDUCER
- CONTROL BOX INCLUDES (3) PUSH BUTTONS: FORWARD, REVERSE, & E-STOP (NOT SHOWN)
- DESIGNED FOR 2000 LB AND 4000 LB CRANES

SPECIAL FEATURES

NONE

PLEASE CIRCLE SPECIFICATIONS:

POWER	<input checked="" type="checkbox"/> AC	<input type="checkbox"/> DC (12V)	<input type="checkbox"/> AIR/OIL
MOTOR VOLTAGE	<input type="checkbox"/> 115	<input type="checkbox"/> 208	<input checked="" type="checkbox"/> 230
DEDICATED CIRCUIT REQUIRED 60Hz			
MOTOR PHASE	<input type="checkbox"/> SINGLE	<input type="checkbox"/> THREE	
CONTROL	<input type="checkbox"/> HAND	<input type="checkbox"/> FOOT	

APPROVAL

I, THE UNDERSIGNED, AGREE THAT THE PRODUCT AS REPRESENTED SATISFIES DESIGN AND DIMENSION REQUIREMENTS. I ALSO ACKNOWLEDGE MY DUTY TO CONFIRM PRODUCT AND INSTALLATION COMPLIANCE WITH ALL APPLICABLE FEDERAL, STATE AND LOCAL REGULATIONS AND STANDARDS.

ANY MODIFIED UNITS ARE NON-RETURNABLE

[] As drawn [] As marked

Signed: _____ Date: _____

Printed Name: _____

LEAD TIME WILL START UPON RECEIPT OF SIGNED APPROVAL DRAWING

FOR INTERNAL USE ONLY PROJECT SIGN OFF	
SALES	
ENG.	
FAB.	
POWER	

DISTRIBUTOR'S NAME:		P.O.#
VESTIL MANUFACTURING		X
DRAWN BY: MTS		DATE: 3/28/2015
REFERENCE: X		SCALE: 1:50
QUOTED LEAD TIME: X		QUOTE #
		X
		FILE NAME:
		28-007-392-001