

# GANTRY POWER TRACTION DRIVE - GPTD-4

APPROX WEIGHT: 257 lbs.  
DOES NOT INCLUDE WEIGHT OF POWER OR PACKAGING!!!

\*\*\* ANY ADDITIONS, DELETIONS, OR OMISSIONS MUST BE CORRECTED ON THIS DRAWING AS THIS DRAWING WILL BE CONSIDERED ALL INCLUSIVE \*\*\*

ALL GRAPHICS PROVIDED ARE FOR REFERENCE ONLY. IF CERTAIN DIMENSIONS ARE CRITICAL PLEASE VERIFY THOSE DIMENSIONS WITH YOUR SALESPERSON

ADJUSTABLE HEIGHT GANTRY CRANE  
SHOWN FOR REFERENCE ONLY.  
SOLD SEPERATLY

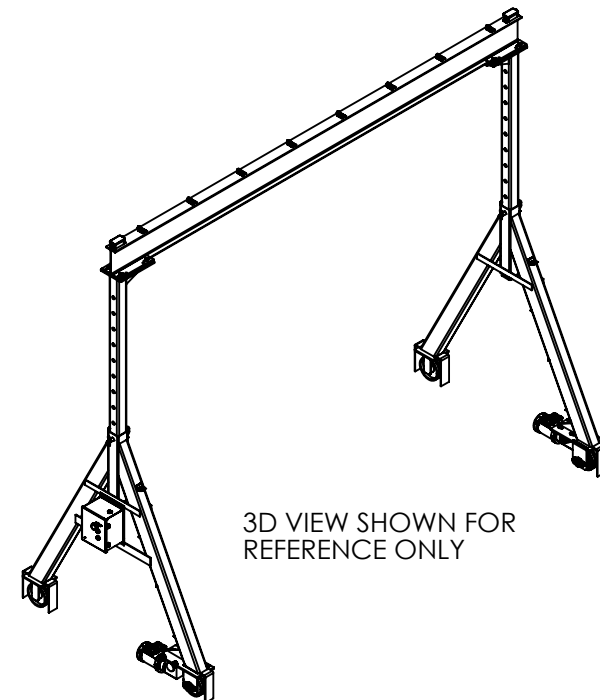
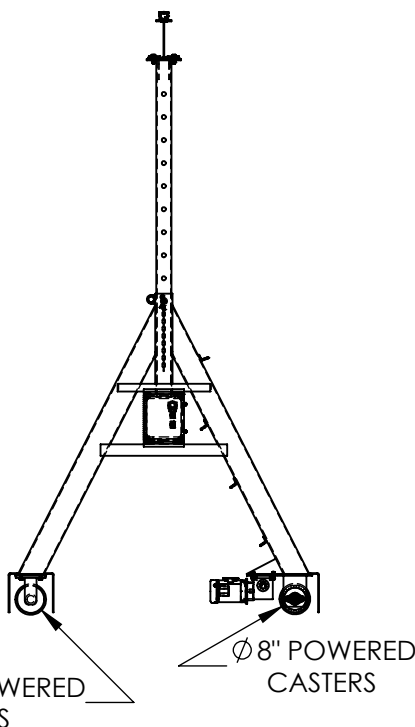
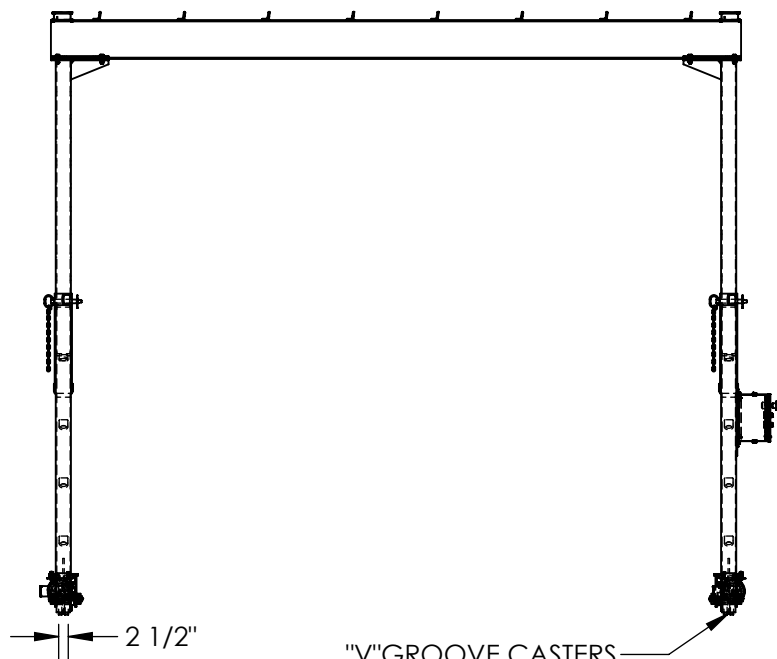

3D VIEW SHOWN FOR REFERENCE ONLY

DIMENSION TOLERANCE  $\pm 1/4"$

## STANDARD FEATURES

- MODEL NUMBER IS GPTD-4
- MAX CAPACITY IS 8000 LB
- WHEEL DIAMETER IS 8"
- WHEEL WIDTH IS 2 1/2"
- (4) CAST IRON "V" GROOVE CASTERS
- (2) CASTERS POWERED BY ELECTRIC MOTOR WITH REDUCER
- CONTROL BOX INCLUDES (3) PUSH BUTTONS:  
FORWARD, REVERSE, & E-STOP (NOT SHOWN)
- DESIGNED FOR 6000 LB AND 8000 LB CRANES

## SPECIAL FEATURES

NONE

## PLEASE CIRCLE SPECIFICATIONS:

POWER	AC	DC (12V)	AIR/OIL
MOTOR VOLTAGE	115	208	230 460
DEDICATED CIRCUIT REQUIRED 60Hz			
MOTOR PHASE	SINGLE	THREE	
CONTROL	HAND	FOOT	

FOR INTERNAL USE ONLY PROJECT SIGN OFF	
SALES	
ENG.	
FAB.	
POWER	

APPROVAL

I, THE UNDERSIGNED, AGREE THAT THE PRODUCT AS REPRESENTED SATISFIES DESIGN AND DIMENSION REQUIREMENTS. I ALSO ACKNOWLEDGE MY DUTY TO CONFIRM PRODUCT AND INSTALLATION COMPLIANCE WITH ALL APPLICABLE FEDERAL, STATE AND LOCAL REGULATIONS AND STANDARDS.

**ANY MODIFIED UNITS ARE NON-RETURNABLE**

[ ] As drawn [ ] As marked

Signed: \_\_\_\_\_ Date: \_\_\_\_\_

Printed Name: \_\_\_\_\_

LEAD TIME WILL START UPON RECEIPT OF SIGNED APPROVAL DRAWING

DISTRIBUTOR'S NAME:		P.O.#
VESTIL MANUFACTURING		X
DRAWN BY: MTS		DATE: 03/28/2015
REFERENCE: X		SCALE: 1:50
QUOTED LEAD TIME: X		QUOTE # X
		W.O.# X
		SALES: X
		FILE NAME: 28-007-392