

BUMP AND DUMP 90° HOPPER - H-150-HD-BD

APPROX WEIGHT: 543 lbs.
DOES NOT INCLUDE WEIGHT OF POWER OR PACKAGING!!!

*** ANY ADDITIONS, DELETIONS, OR OMISSIONS MUST BE CORRECTED ON THIS DRAWING AS THIS DRAWING WILL BE CONSIDERED ALL INCLUSIVE ***

ALL GRAPHICS PROVIDED ARE FOR REFERENCE ONLY. IF CERTAIN DIMENSIONS ARE CRITICAL PLEASE VERIFY THOSE DIMENSIONS WITH YOUR SALESPERSON

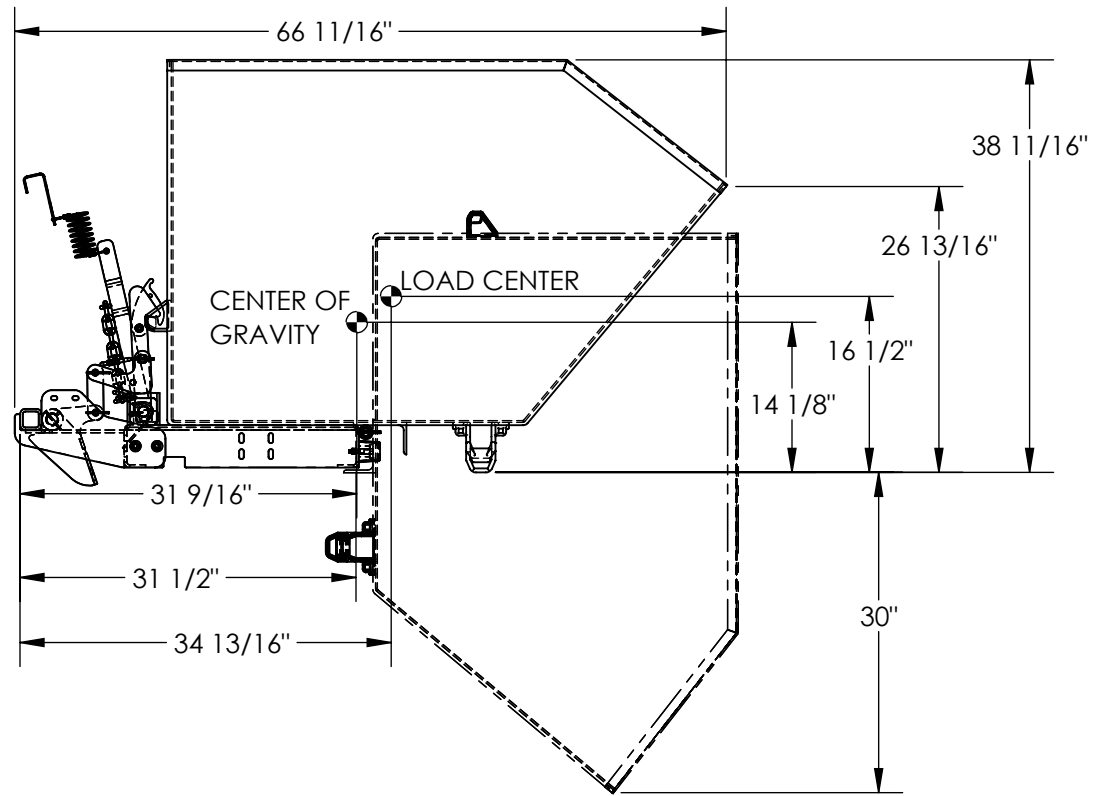
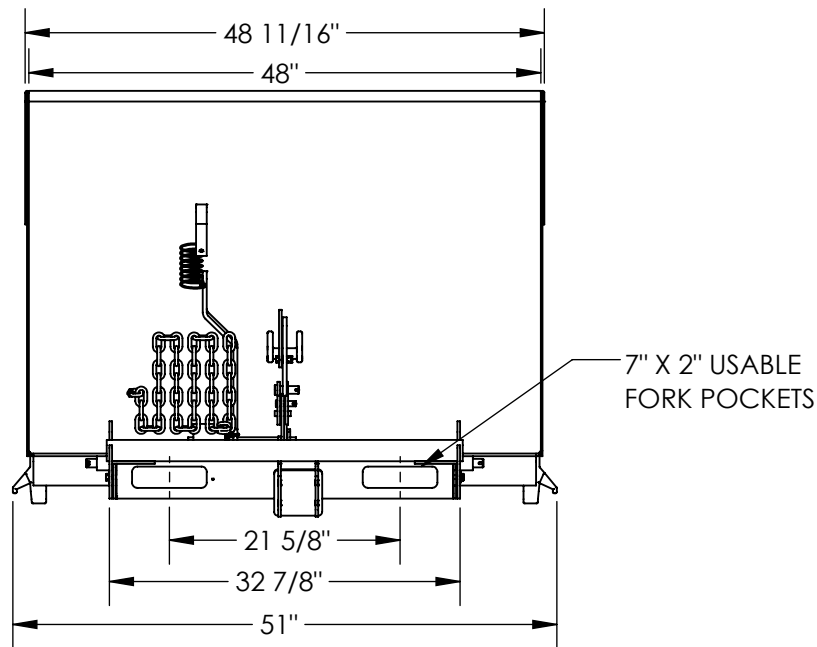

APPROX. WEIGHT / LOST LOAD = 543 LBS.

MINIMUM EFFECTIVE THICKNESS =

FORK LENGTH MINUS 31 1/2"

NEVER EXCEED LOAD CENTER

RATING PER FORKTRUCK

MANUFACTURERS GUIDELINES.

DO NOT USE THIS FORK TRUCK

ATTACHMENT IF LOAD WILL

EXCEED FORK TRUCK MANUFACTURER'S

LOAD CENTER RATING

**** ADDITION OF CASTERS MAY
CHANGE WEIGHT CAPACITY
BASED ON CASTER RATING**

DIMENSION TOLERANCE ± 1/4"

STANDARD FEATURES

MODEL NUMBER IS H-150-HD-BD

OVERALL WIDTH IS 51"

INSIDE WIDTH IS 48"

OVERALL LENGTH IS 66 11/16"

OVERALL HEIGHT IS 38 11/16"

MAX CAPACITY IS 6,000 LBS.

VOLUME IS 1.5 CU. YRDS.

HOPPER IS TOUGH BAKED IN POWDER

COATED BLUE FINISH

BUMP AND DUMP MECHANISM IS

TOUGH BAKED IN POWDER COATED YELLOW FINISH

SPECIAL FEATURES

NONE

APPROVAL

I, THE UNDERSIGNED, AGREE THAT THE PRODUCT AS REPRESENTED SATISFIES DESIGN AND DIMENSION REQUIREMENTS. I ALSO ACKNOWLEDGE MY DUTY TO CONFIRM PRODUCT AND INSTALLATION COMPLIANCE WITH ALL APPLICABLE FEDERAL, STATE AND LOCAL REGULATIONS AND STANDARDS.
UNITS REQUIRING APPROVAL DRAWINGS OR MODIFIED ARE NON-RETURNABLE

[] As drawn [] As marked

Signed: _____ Date: _____

Printed Name: _____

LEAD TIME WILL START UPON RECEIPT OF SIGNED APPROVAL DRAWING

DISTRIBUTOR'S NAME:		P.O.#
VESTIL MANUFACTURING		X
DRAWN BY: JWW		W.O.#
DATE: 2/3/2022		X
REFERENCE: X	SCALE: 1:18	SALES: X
QUOTED LEAD TIME: X	QUOTE #	FILE NAME:
	X	37-007-188