

# HYDRA LIFT CART - HYDRA-2

APPROX WEIGHT: 211.90 lbs.  
DOES NOT INCLUDE WEIGHT OF POWER OR PACKAGING!!!

\*\*\* ANY ADDITIONS, DELETIONS, OR OMISSIONS MUST BE CORRECTED ON THIS DRAWING AS THIS DRAWING WILL BE CONSIDERED ALL INCLUSIVE \*\*\*  
ALL GRAPHICS PROVIDED ARE FOR REFERENCE ONLY. IF CERTAIN DIMENSIONS ARE CRITICAL PLEASE VERIFY THOSE DIMENSIONS WITH YOUR SALESPERSON

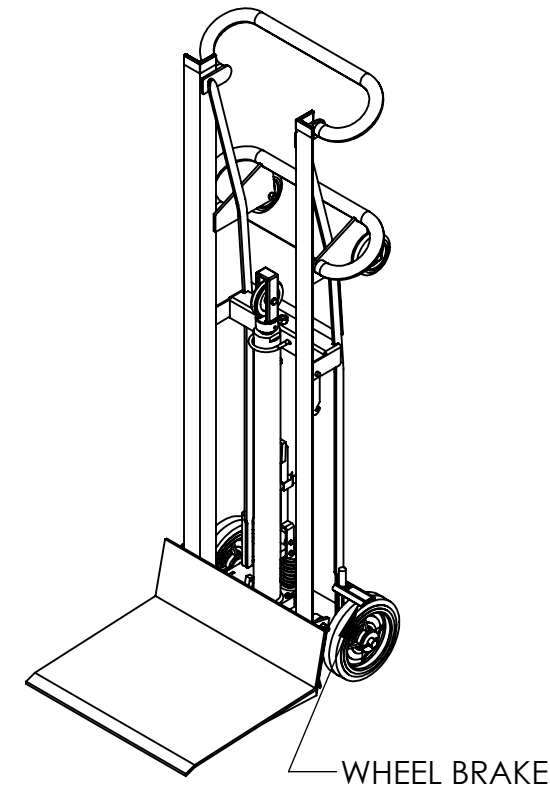
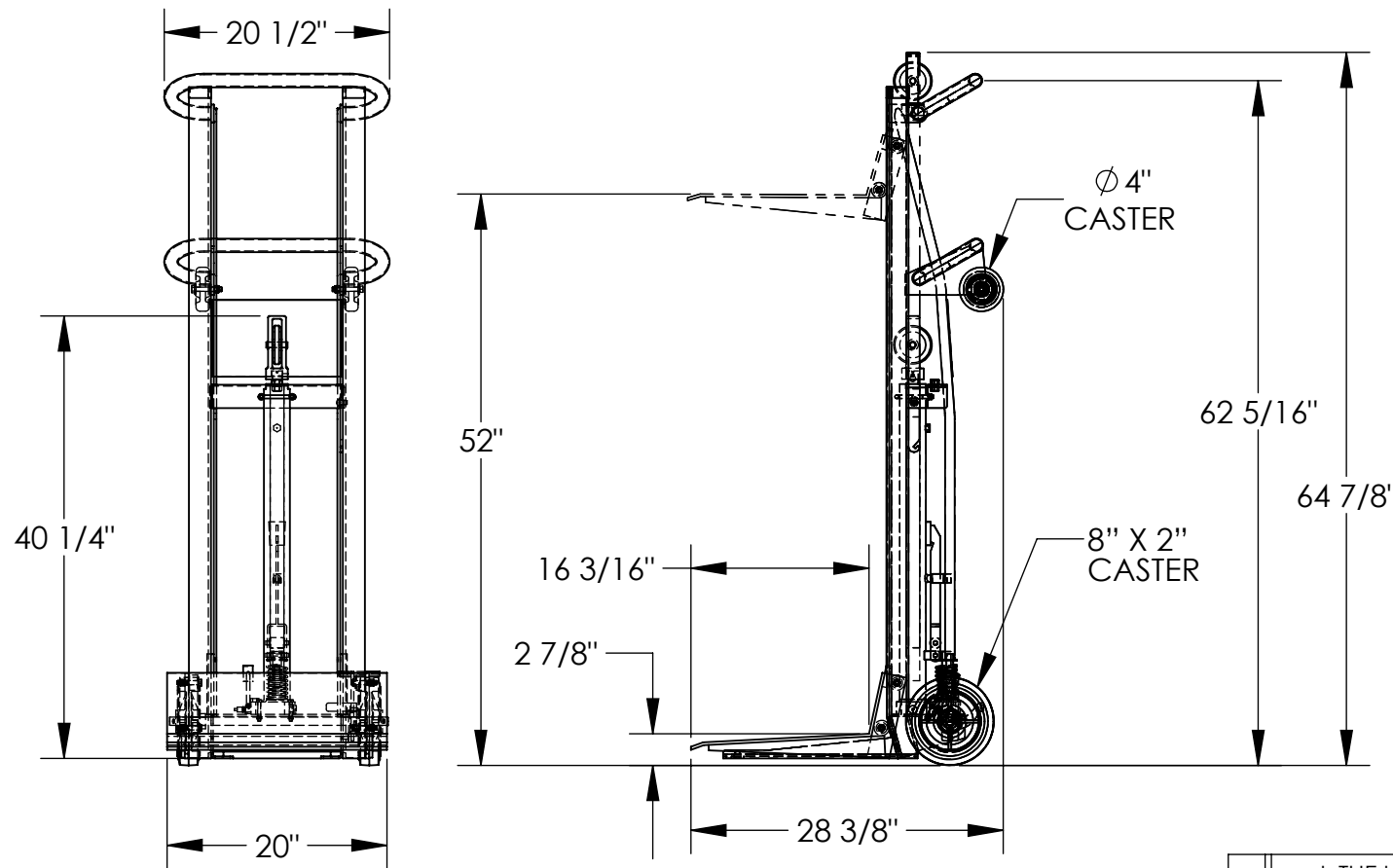

DIMENSION TOLERANCE ± 1/4"

## STANDARD FEATURES

- MODEL NUMBER: HYDRA-2
- CAPACITY: 750 LBS
- OVERALL WIDTH: 20 1/2"
- OVERALL LENGTH: 28 3/8"
- OVERALL HEIGHT: 64 7/8" (FULLY RAISED)
- PLATFORM SIZE: 20" WIDE x 16 3/16" LONG
- SERVICE RANGE: 2 7/8" TO 52"
- 8" x 2" POLY ON POLY WHEELS IN BACK
- SINGLE WHEEL BRAKE
- FOOT PUMP OPERATION
- TOUGH BAKED IN POWDER COATED BLUE FINISH

## SPECIAL FEATURES

NONE

**APPROVAL**

I, THE UNDERSIGNED, AGREE THAT THE PRODUCT AS REPRESENTED SATISFIES DESIGN AND DIMENSION REQUIREMENTS. I ALSO ACKNOWLEDGE MY DUTY TO CONFIRM PRODUCT AND INSTALLATION COMPLIANCE WITH ALL APPLICABLE FEDERAL, STATE AND LOCAL REGULATIONS AND STANDARDS.

**UNITS REQUIRING APPROVAL DRAWINGS OR MODIFIED ARE NON-RETURNABLE**

As drawn     As marked

Signed: \_\_\_\_\_ Date: \_\_\_\_\_

Printed Name: \_\_\_\_\_

LEAD TIME WILL START UPON RECEIPT OF SIGNED APPROVAL DRAWING

DISTRIBUTOR'S NAME:		P.O.#
VESTIL MANUFACTURING		X
DRAWN BY: DLS	DATE: 9/10/2015	W.O.#
REFERENCE: X	SCALE: 1:16	X
QUOTED LEAD TIME: X	QUOTE #	SALES: X
	X	FILE NAME:
		33-007-105