

TRANSPORTABLE JIB CRANE - JIB-P-10-6-8

APPROX WEIGHT: 613.40 lbs.
DOES NOT INCLUDE WEIGHT OF POWER OR PACKAGING!!!

*** ANY ADDITIONS, DELETIONS, OR OMISSIONS MUST BE CORRECTED ON THIS DRAWING AS THIS DRAWING WILL BE CONSIDERED ALL INCLUSIVE ***

ALL GRAPHICS PROVIDED ARE FOR REFERENCE ONLY. IF CERTAIN DIMENSIONS ARE CRITICAL PLEASE VERIFY THOSE DIMENSIONS WITH YOUR SALESPERSON

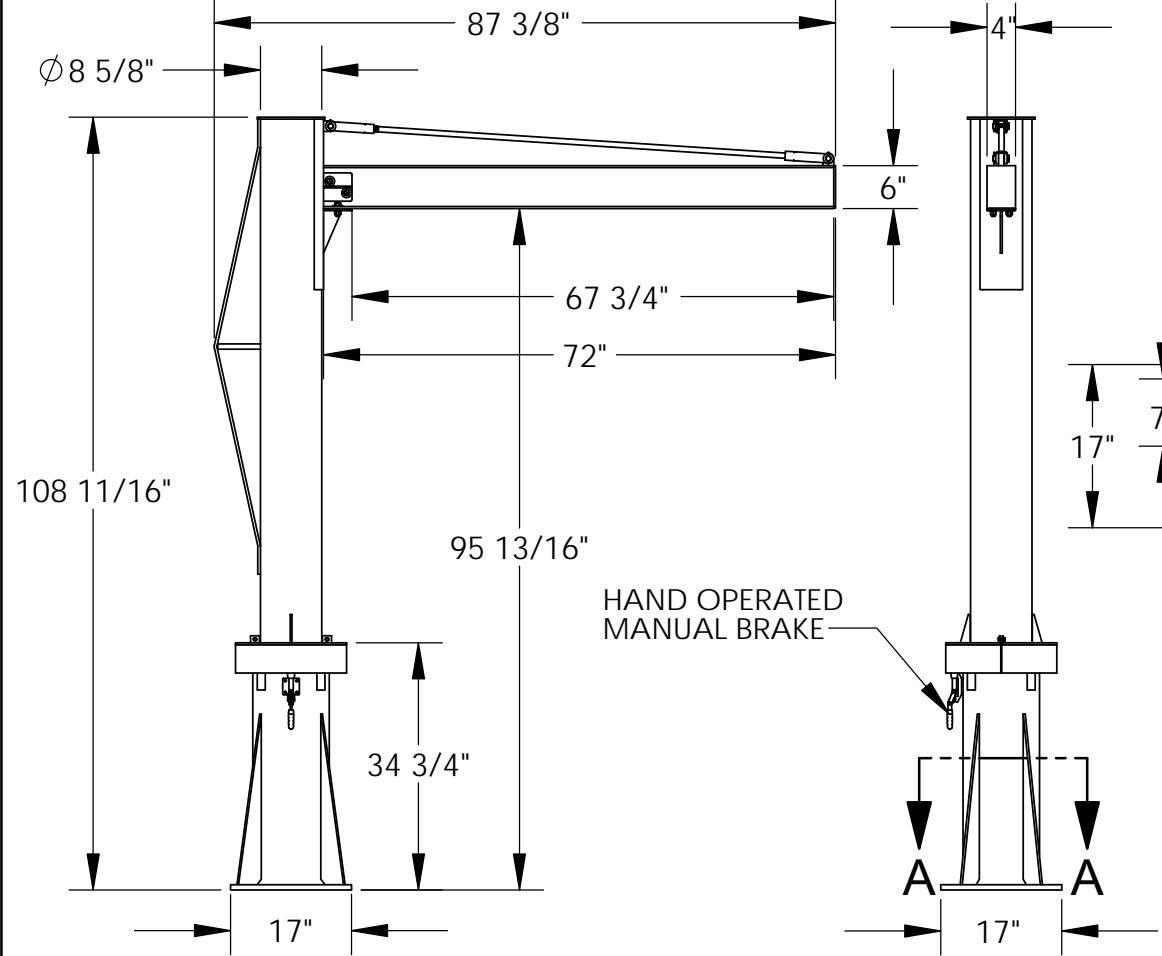

STANDARD FEATURES

- MODEL NUMBER: JIB-P-10-6-8
- CAPACITY: 1,000 POUNDS
- OVERALL LENGTH: 87 3/8"
- OVERALL BOOM LENGTH: 72"
- USABLE BOOM LENGTH: 67 3/4"
- OVERALL HEIGHT: 108 11/16"
- USABLE HEIGHT: 95 13/16"
- I-BEAM SIZE: 6" HEIGHT X 4" FLANGE WIDTH
- UPRIGHT PIPE DIAMETER: 8 5/8"
- BASE SIZE: 17" X 17" X 34 3/4"
- WITH MOUNTING HOLES: Ø 1"
- 360° CONTINUOUS ROTATION
- HAND OPERATED MANUAL BRAKE
- BLUE WATER BASED PAINT FINISH

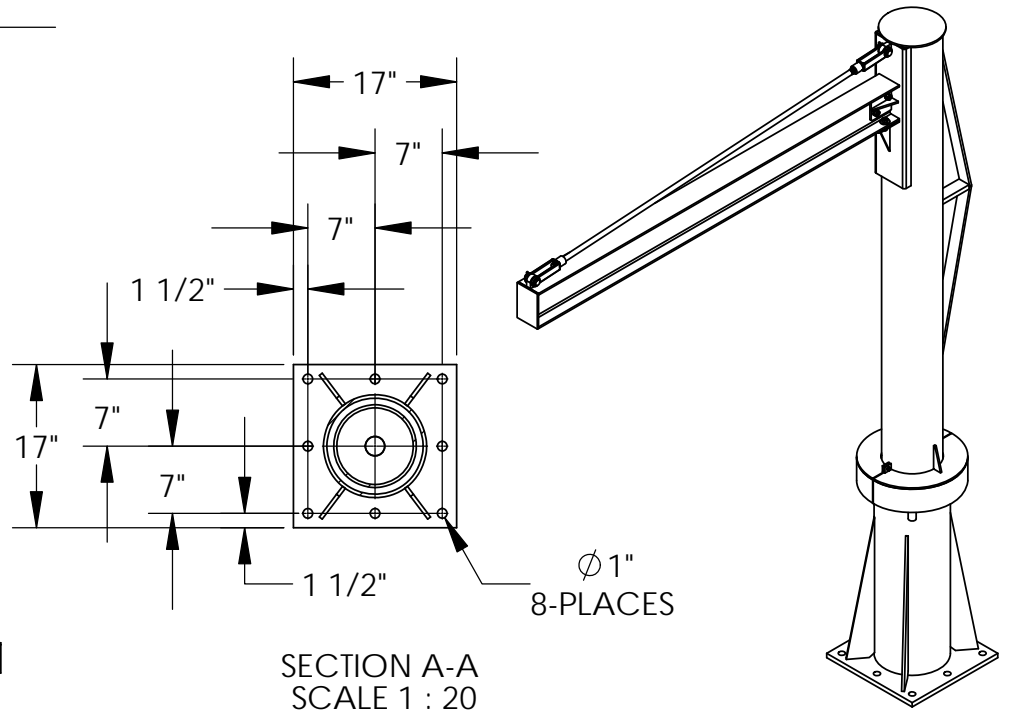

SPECIAL FEATURES

NONE

SECTION A-A
SCALE 1 : 20

SPECIAL FOUNDATION MAY BE REQUIRED: SEE OWNERS MANUAL FOR DETAILS
3D VIEW SHOWN FOR REFERENCE ONLY

DIMENSION TOLERANCE ± 1/4"

I, THE UNDERSIGNED, AGREE THAT THE PRODUCT AS REPRESENTED SATISFIES DESIGN AND DIMENSION REQUIREMENTS. I ALSO ACKNOWLEDGE MY DUTY TO CONFIRM PRODUCT AND INSTALLATION COMPLIANCE WITH ALL APPLICABLE FEDERAL, STATE AND LOCAL REGULATIONS AND STANDARDS.

ANY MODIFIED UNITS ARE NON-RETURNABLE

[] As drawn [] As marked

Signed: _____ Date: _____

Printed Name: _____

LEAD TIME WILL START UPON RECEIPT OF SIGNED APPROVAL DRAWING

APPROVAL

FOR INTERNAL USE ONLY PROJECT SIGN OFF	
SALES	
ENG.	
FAB.	
POWER	

DISTRIBUTOR'S NAME:		P.O.#
VESTIL MANUFACTURING		X
DRAWN BY: ND		W.O.#
DATE: 8/14/09		X
REFERENCE: X	SCALE: 1:27	SALES: X
QUOTED LEAD TIME: X	QUOTE # X	FILE NAME:
		28-007-121