

LINEAR ACTUATED ADJUSTABLE-HEIGHT WORK BENCH - LAW-3636

APPROX WEIGHT: 213.44 lbs.
DOES NOT INCLUDE WEIGHT OF POWER OR PACKAGING!!!

*** ANY ADDITIONS, DELETIONS, OR OMISSIONS MUST BE CORRECTED ON THIS DRAWING AS THIS DRAWING WILL BE CONSIDERED ALL INCLUSIVE ***

ALL GRAPHICS PROVIDED ARE FOR REFERENCE ONLY. IF CERTAIN DIMENSIONS ARE CRITICAL PLEASE VERIFY THOSE DIMENSIONS WITH YOUR SALESPERSON

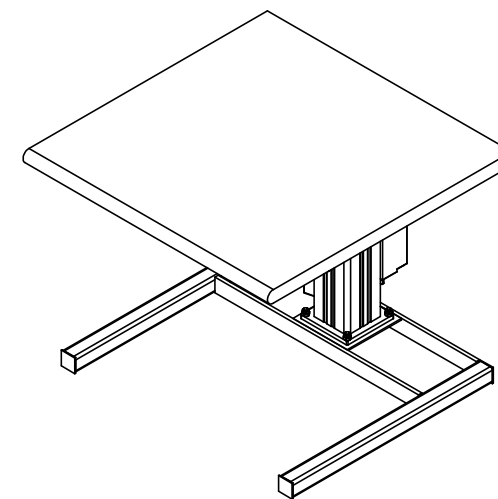
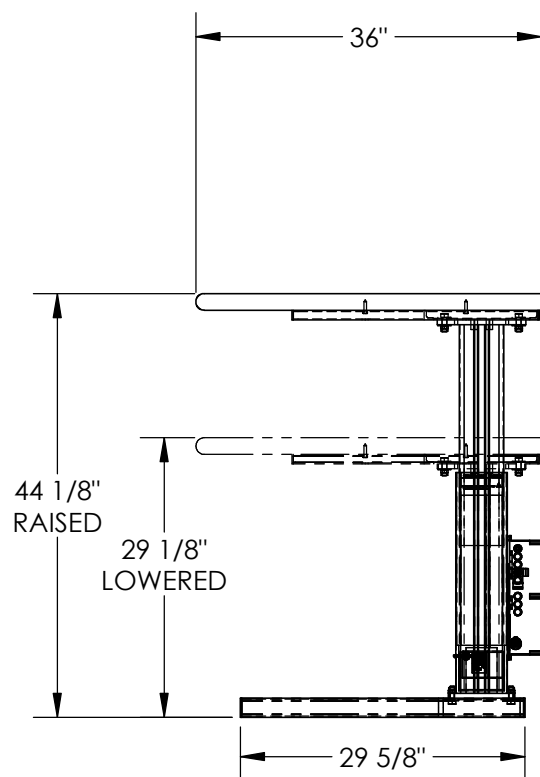
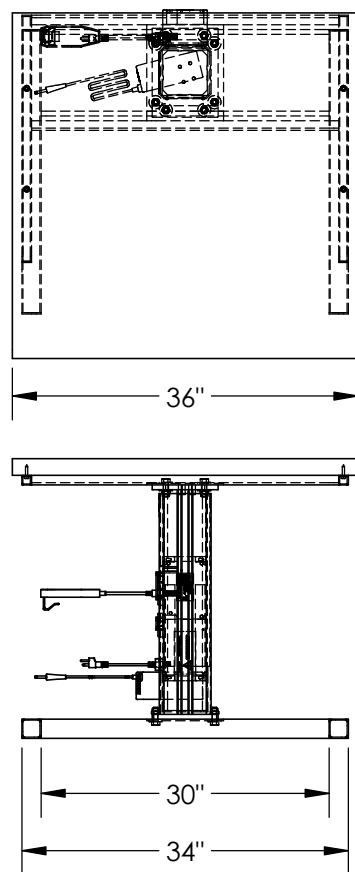

FOR INTERNAL USE ONLY PROJECT SIGN OFF	
SALES	
ENG.	
FAB.	
POWER	

DIMENSION TOLERANCE ± 1/4"

STANDARD FEATURES

- MODEL NUMBER IS LAW-3636
- OVERALL WIDTH IS 36"
- USABLE WIDTH IS 36"
- OVERALL LENGTH IS 36"
- USABLE LENGTH IS 36"
- RAISED HEIGHT IS 44 1/8"
- LOWERED HEIGHT IS 29 1/8"
- MAX UNIFORM CAPACITY IS 500 LBS.
- LINEAR ACTUATOR POWERED HEIGHT ADJUSTMENT

POWER SPECIFICATIONS

- *DC (24V) POWER
- *HAND CONTROL
- *ON-BOARD CHARGER

SPECIAL FEATURES

NONE

APPROVAL

I, THE UNDERSIGNED, AGREE THAT THE PRODUCT AS REPRESENTED SATISFIES DESIGN AND DIMENSION REQUIREMENTS. I ALSO ACKNOWLEDGE MY DUTY TO CONFIRM PRODUCT AND INSTALLATION COMPLIANCE WITH ALL APPLICABLE FEDERAL, STATE AND LOCAL REGULATIONS AND STANDARDS.
ALL SPECIAL UNITS ARE NON-RETURNABLE
[] As drawn [] As marked

Signed: _____ Date: _____

LEAD TIME WILL START UPON RECEIPT OF SIGNED APPROVAL DRAWING

DISTRIBUTOR'S NAME:		P.O.#
VESTIL MANUFACTURING		X
W.O.#		X
DRAWN BY: B.NOETHNAGEL	DATE: 12/2/2015	SALES: X
REFERENCE: X	SCALE: 1:20	FILE NAME:
QUOTED LEAD TIME: X	QUOTE # X	43-007-004