

LIFT MASTER BOOM, ORBIT NON-TELESCOPING BOOM-LM-OBNT-6-24

APPROX WEIGHT: 398.39 lbs.
DOES NOT INCLUDE WEIGHT OF POWER OR PACKAGING!!!

*** ANY ADDITIONS, DELETIONS, OR OMISSIONS MUST BE CORRECTED ON THIS DRAWING AS THIS DRAWING WILL BE CONSIDERED ALL INCLUSIVE ***
ALL GRAPHICS PROVIDED ARE FOR REFERENCE ONLY. IF CERTAIN DIMENSIONS ARE CRITICAL PLEASE VERIFY THOSE DIMENSIONS WITH YOUR SALESPERSON

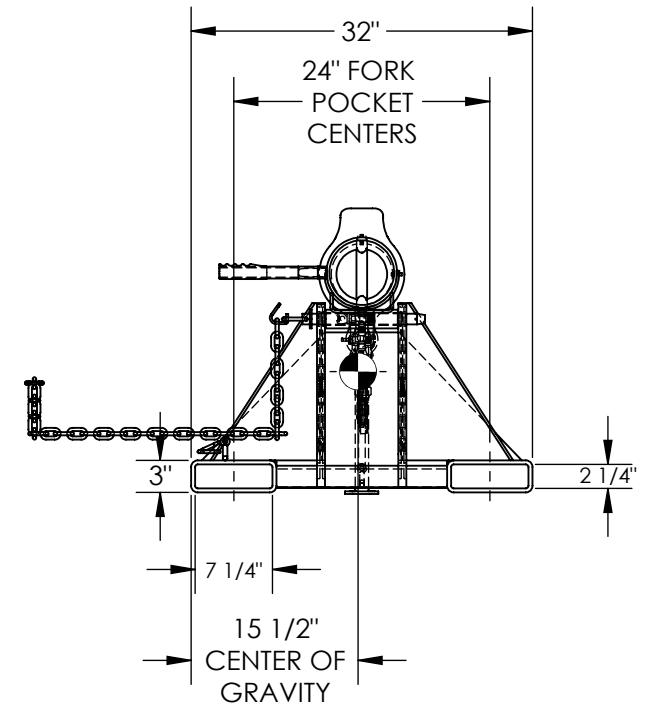
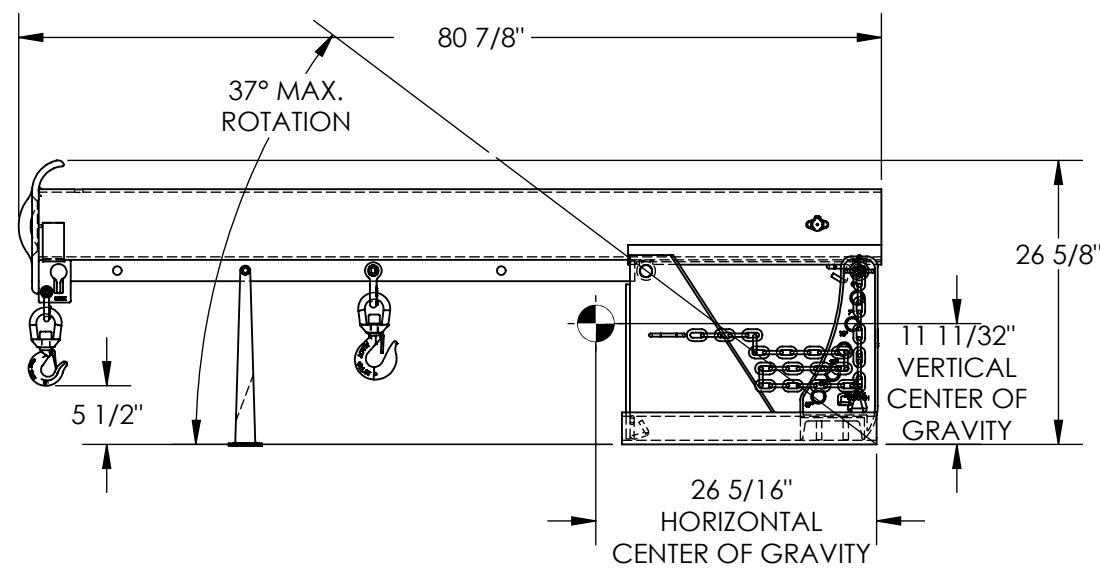

*--MAXIMUM SINGLE HOOK CAPACITIES

| DISTANCE | 36" | 48" | 60" | 72" | 78" |
|----------|------|------|------|------|------|
| CAPACITY | 6000 | 5000 | 4500 | 4000 | 3500 |

STANDARD FEATURES

- MODEL NUMBER IS LM-OBNT-6-24
- CAPACITY IS 6,000 LBS
- MAXIMUM TILT ANGLE IS 37°
- OVERALL HEIGHT - 26 5/8"
- HEIGHT (MAX TILTED) - 57 3/16"
- OVERALL LENGTH - 80 7/8"
- OVERALL WIDTH IS 32"
- 36" MINIMUM HOOK POINT
- 78" MAXIMUM HOOK POINT
- HOOK HEIGHT - 5 1/2"
- HOOK HEIGHT (MAX TILTED) - 38 1/4"
- USABLE FORK POCKET - 2 1/4"x7 1/4"
- 24" FORK POCKET CENTERS
- TOUGH BAKED IN POWDER COATED BLUE FINISH

APPROX. WEIGHT / LOST LOAD = 398.39
 MINIMUM EFFECTIVE THICKNESS = LESS THAN 1"
 NEVER EXCEED LOAD CENTER
 RATING PER FORKTRUCK
 MANUFACTURERS GUIDELINES.
 DO NOT USE THIS FORK TRUCK
 ATTACHMENT IF LOAD WILL
 EXCEED FORK TRUCK MANUFACTURER'S
 LOAD CENTER RATING

SPECIAL FEATURES

NONE

DIMENSION TOLERANCE ± 1/4"

| | | |
|---|--|-------------|
| APPROVAL | I, THE UNDERSIGNED, AGREE THAT THE PRODUCT AS REPRESENTED SATISFIES DESIGN AND DIMENSION REQUIREMENTS. I ALSO ACKNOWLEDGE MY DUTY TO CONFIRM PRODUCT AND INSTALLATION COMPLIANCE WITH ALL APPLICABLE FEDERAL, STATE AND LOCAL REGULATIONS AND STANDARDS. | |
| | UNITS REQUIRING APPROVAL DRAWINGS OR MODIFIED ARE NON-RETURNABLE | |
| | [] As drawn [] As marked | |
| Signed: _____ | | Date: _____ |
| Printed Name: _____ | | |
| LEAD TIME WILL START UPON RECEIPT OF SIGNED APPROVAL DRAWING | | |

| | | |
|-----------------------|-------------|------------|
| DISTRIBUTOR'S NAME: | | P.O.# |
| VESTIL MANUFACTURING | | X |
| DRAWN BY: B.NOTHNAGEL | | W.O.# |
| DATE: 7/2/2015 | | X |
| REFERENCE: X | SCALE: 1:18 | SALES: X |
| QUOTED LEAD TIME: X | QUOTE # | FILE NAME: |
| | X | 08-007-136 |