

INTERNESTABLE RACK W/ ADJUSTABLE POST - NEST-F-6048

APPROX WEIGHT: 185.64 lbs.
 DOES NOT INCLUDE WEIGHT OF POWER OR PACKAGING!!!

*** ANY ADDITIONS, DELETIONS, OR OMISSIONS MUST BE CORRECTED ON THIS DRAWING AS THIS DRAWING WILL BE CONSIDERED ALL INCLUSIVE ***
 ALL GRAPHICS PROVIDED ARE FOR REFERENCE ONLY. IF CERTAIN DIMENSIONS ARE CRITICAL PLEASE VERIFY THOSE DIMENSIONS WITH YOUR SALESPERSON

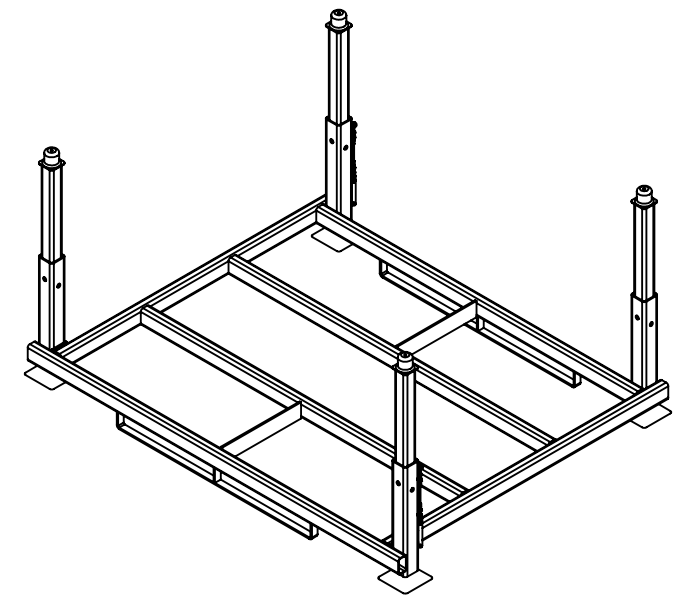
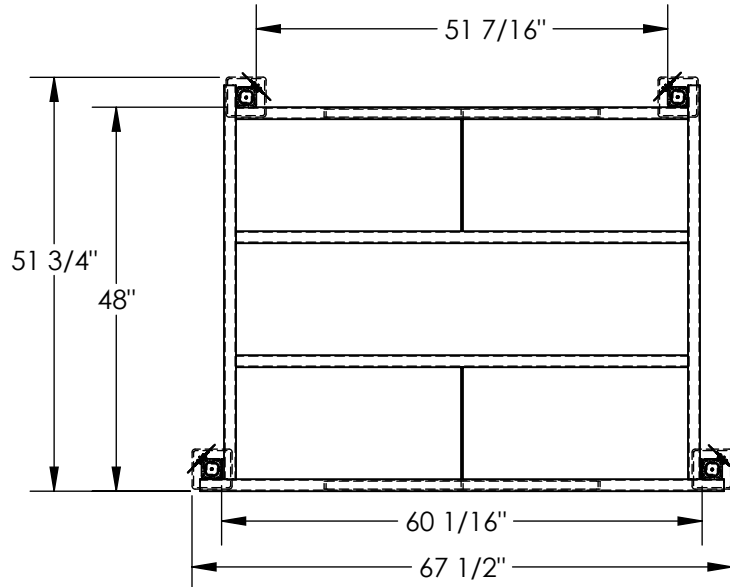

STANDARD FEATURES

- MODEL NUMBER IS NEST-F-6048
- OVERALL WIDTH IS 67 1/2"
- USABLE WIDTH IS 60 1/16"
- OVERALL LENGTH IS 51 3/4"
- USABLE LENGTH IS 48"
- LOWERED HEIGHT IS 29 3/16"
- RAISED HEIGHT 35 3/16"
- MAX CAPACITY IS 4000 lbs
- TOUGH BAKED IN POWDER COATED ERGO BLUE FINISH

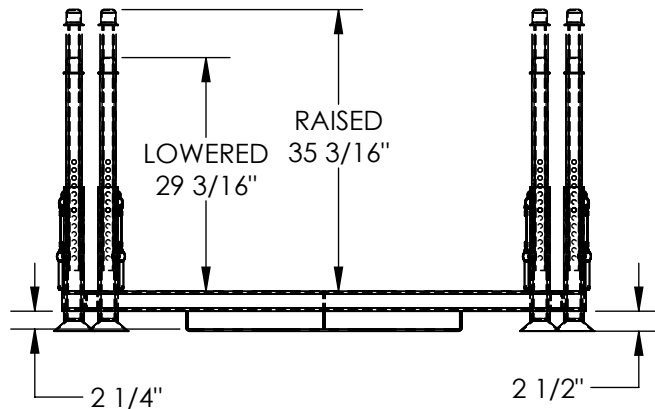

DIMENSION TOLERANCE ± 1/4"

I, THE UNDERSIGNED, AGREE THAT THE PRODUCT AS REPRESENTED SATISFIES DESIGN AND DIMENSION REQUIREMENTS. I ALSO ACKNOWLEDGE MY DUTY TO CONFIRM PRODUCT AND INSTALLATION COMPLIANCE WITH ALL APPLICABLE FEDERAL, STATE AND LOCAL REGULATIONS AND STANDARDS.

UNITS REQUIRING APPROVAL DRAWINGS OR MODIFIED ARE NON-RETURNABLE

As drawn As marked

Signed: _____ Date: _____

Printed Name: _____

LEAD TIME WILL START UPON RECEIPT OF SIGNED APPROVAL DRAWING

SPECIAL FEATURES

NONE

DISTRIBUTOR'S NAME:		P.O.#
VESTIL MANUFACTURING		X
DRAWN BY: TAL		W.O.#
DATE: 9/30/2016		X
REFERENCE: X	SCALE: 1:24	SALES: X
QUOTED LEAD TIME: X	QUOTE #	FILE NAME:
	X	31-007-243