

(ROLL PALLET TRUCK) - PM4-4048-RL

*** ANY ADDITIONS, DELETIONS, OR OMISSIONS MUST BE CORRECTED ON THIS DRAWING AS THIS DRAWING WILL BE CONSIDERED ALL INCLUSIVE ***
 ALL GRAPHICS PROVIDED ARE FOR REFERENCE ONLY. IF CERTAIN DIMENSIONS ARE CRITICAL PLEASE VERIFY THOSE DIMENSIONS WITH YOUR SALESPERSON

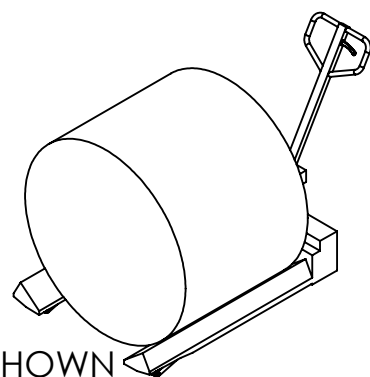

ROLL SHOWN FOR REFERENCE ONLY

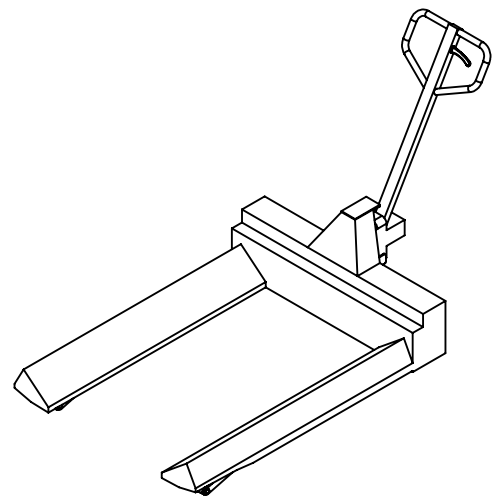
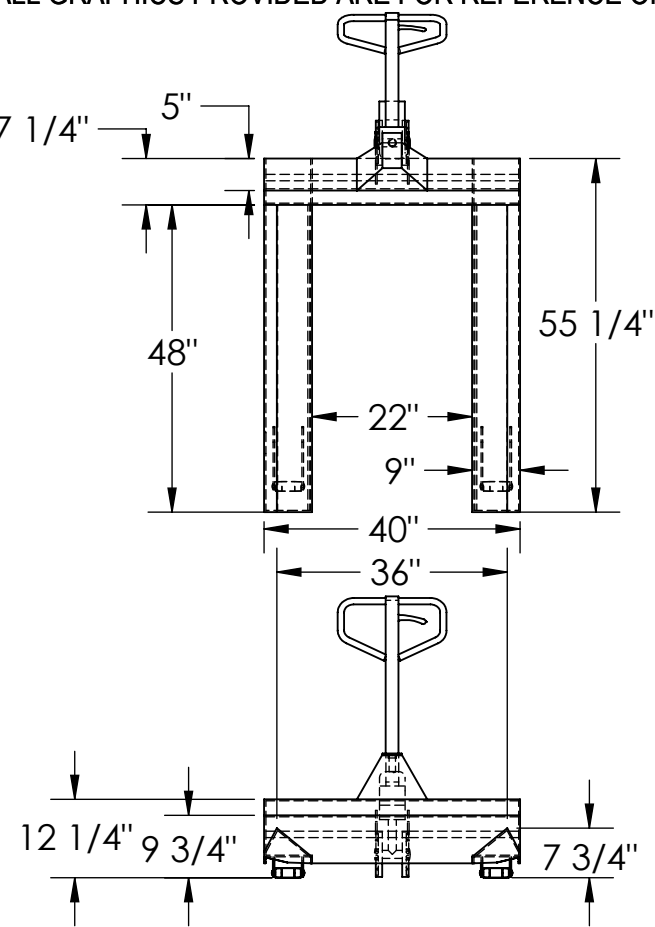
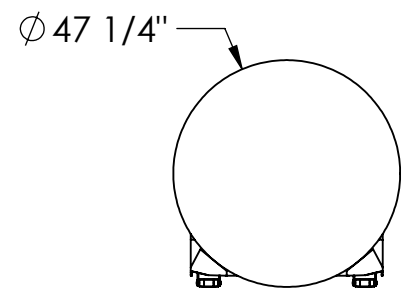
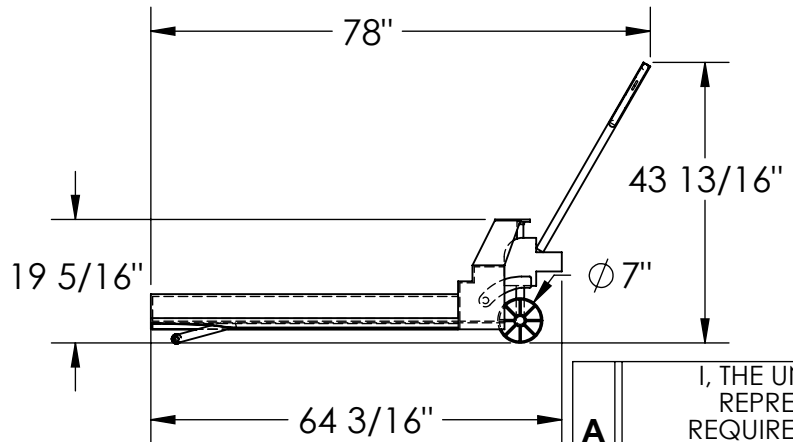

STANDARD FEATURES

- MODEL NUMBER IS PM4-4048-RL
- OVERALL WIDTH IS 40"
- USABLE WIDTH IS 22"
- OVERALL LENGTH WITHOUT HANDLE IS 64 3/16"
- USABLE LENGTH IS 48"
- OVERALL HEIGHT WITHOUT HANDLE IS 19 5/16"
- MAX CAPACITY IS 4000 LBS. UNIFORM
- TOUGH BAKED IN POWDER COATED YELLOW FINISH
- OVERALL MEASUREMENTS WITH HANDLE WILL VARY DEPENDING ON RESTING POSITION
- LENGTH WITH HANDLE IS 78"
- HEIGHT WITH HANDLE IS 43 13/16"

APPROX WEIGHT: 360 lbs.
 DOES NOT INCLUDE WEIGHT OF POWER OR PACKAGING!!!

SPECIAL FEATURES
 NONE

DIMENSION TOLERANCE ± 1/2"

APPROVAL

I, THE UNDERSIGNED, AGREE THAT THE PRODUCT AS REPRESENTED SATISFIES DESIGN AND DIMENSION REQUIREMENTS. I ALSO ACKNOWLEDGE MY DUTY TO CONFIRM PRODUCT AND INSTALLATION COMPLIANCE WITH ALL APPLICABLE FEDERAL, STATE AND LOCAL REGULATIONS AND STANDARDS.

ANY MODIFIED UNITS ARE NON-RETURNABLE

[] As drawn [] As marked

Signed: _____ Date: _____

Printed Name: _____

LEAD TIME WILL START UPON RECEIPT OF SIGNED APPROVAL DRAWING

FOR INTERNAL USE ONLY PROJECT SIGN OFF	
SALES	
ENG.	
FAB.	
POWER	

DISTRIBUTOR'S NAME:		P.O.#
VESTIL MANUFACTURING		X
DRAWN BY: X		W.O.#
DATE: XX/XX/XX		X
REFERENCE: X	SCALE: 1:30	SALES: X
QUOTED LEAD TIME: X	QUOTE # X	FILE NAME:
		15-007-142