

WHEEL RISER CADDY - R-CAD-KIT

APPROX WEIGHT: 1.02 lbs.
 DOES NOT INCLUDE WEIGHT OF POWER OR PACKAGING!!!

*** ANY ADDITIONS, DELETIONS, OR OMISSIONS MUST BE CORRECTED ON THIS DRAWING AS THIS DRAWING WILL BE CONSIDERED ALL INCLUSIVE ***

ALL GRAPHICS PROVIDED ARE FOR REFERENCE ONLY. IF CERTAIN DIMENSIONS ARE CRITICAL PLEASE VERIFY THOSE DIMENSIONS WITH YOUR SALESPERSON

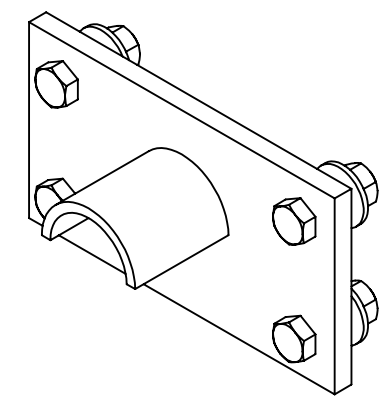
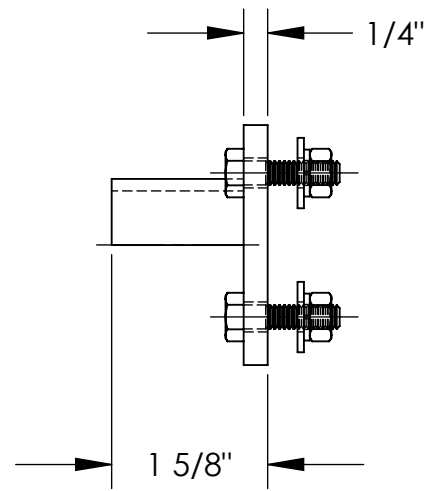
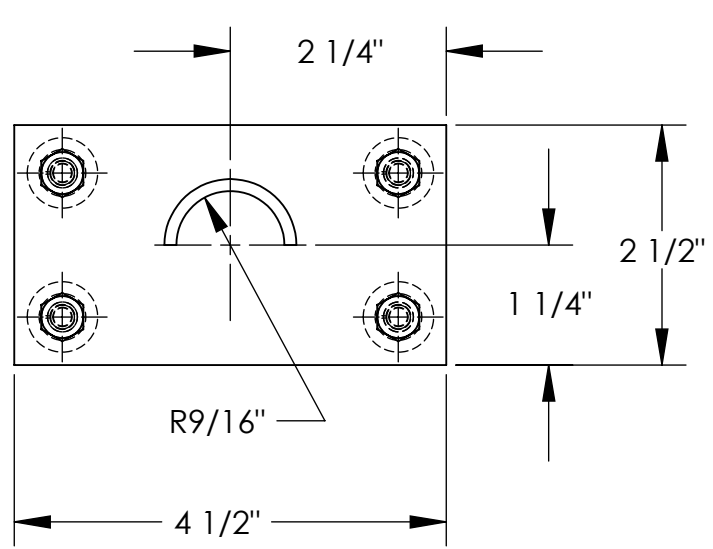

STANDARD FEATURES

- MODEL NUMBER IS R-CAD-KIT
- OVERALL WIDTH IS 4 1/2"
- OVERALL HEIGHT IS 2 1/2"
- OVERALL DEPTH IS 1 5/8"
- POWDER COATED YELLOW
- HARDWARE INCLUDED
- (1) PAIR OF BRACKETS INCLUDED PER KIT
- *FACTORY INSTALLED
 - SWR - WELDED ON
 - ATWR - BOLTED ON
- *FIELD INSTALLED (CUSTOMER TO DRILL HOLES)
 - SWR - BOLTED ON
 - ATWR - BOLTED ON

SPECIAL FEATURES

NONE

DIMENSION TOLERANCE ± 1/4"

APPROVAL	I, THE UNDERSIGNED, AGREE THAT THE PRODUCT AS REPRESENTED SATISFIES DESIGN AND DIMENSION REQUIREMENTS. I ALSO ACKNOWLEDGE MY DUTY TO CONFIRM PRODUCT AND INSTALLATION COMPLIANCE WITH ALL APPLICABLE FEDERAL, STATE AND LOCAL REGULATIONS AND STANDARDS.	
	ANY MODIFIED UNITS ARE NON-RETURNABLE	
	[] As drawn [] As marked	
	Signed: _____ Date: _____	
Printed Name: _____		
<i>LEAD TIME WILL START UPON RECEIPT OF SIGNED APPROVAL DRAWING</i>		

FOR INTERNAL USE ONLY PROJECT SIGN OFF	
SALES	
ENG.	
FAB.	
POWER	

DISTRIBUTOR'S NAME:		P.O.#
VESTIL MANUFACTURING		X
DRAWN BY: X		W.O.#
DATE: XX/XX/XX		X
REFERENCE: X	SCALE: 1:2	SALES: X
QUOTED LEAD TIME: X	QUOTE #	FILE NAME:
	X	18-007-192