

RAIL CAR WHEEL CHOCK - RC-WC

APPROX WEIGHT: 1.84 lbs.
 DOES NOT INCLUDE WEIGHT OF POWER OR PACKAGING!!!

*** ANY ADDITIONS, DELETIONS, OR OMISSIONS MUST BE CORRECTED ON THIS DRAWING AS THIS DRAWING WILL BE CONSIDERED ALL INCLUSIVE ***
 ALL GRAPHICS PROVIDED ARE FOR REFERENCE ONLY. IF CERTAIN DIMENSIONS ARE CRITICAL PLEASE VERIFY THOSE DIMENSIONS WITH YOUR SALESPERSON

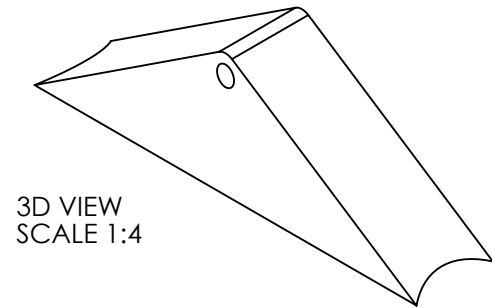
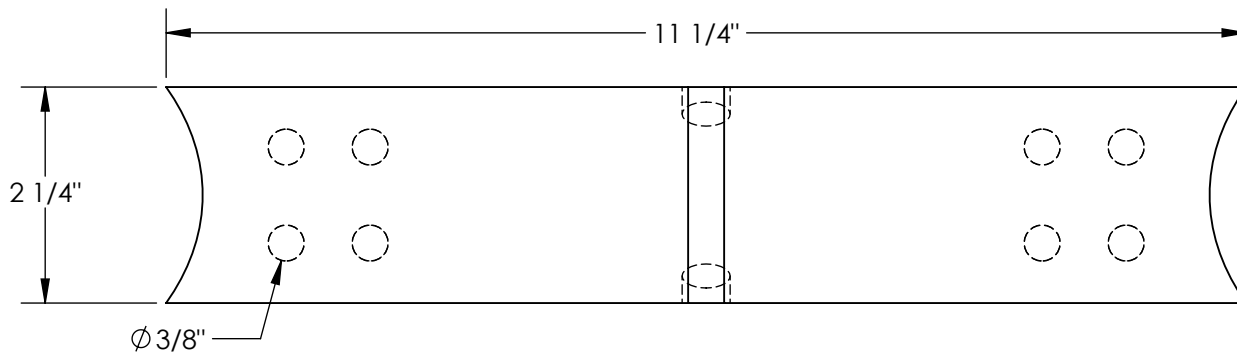

3D VIEW
 SCALE 1:4

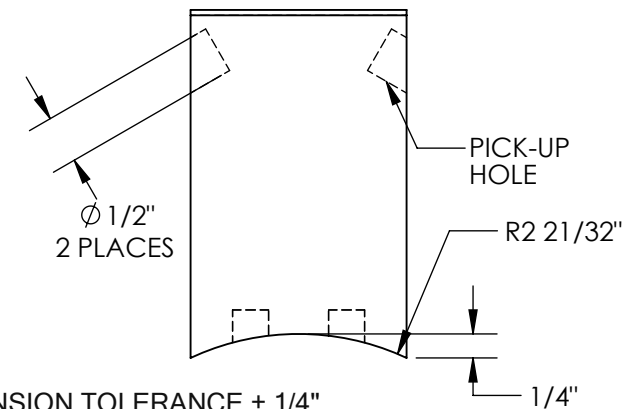
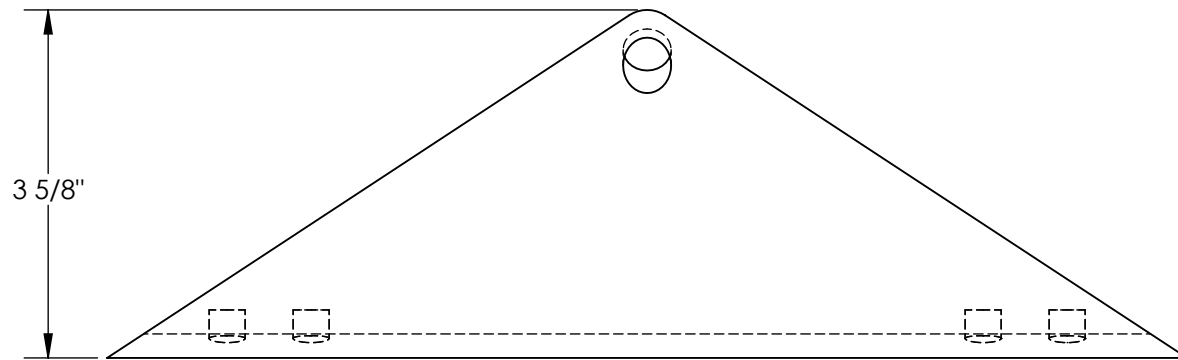

DIMENSION TOLERANCE $\pm 1/4$ "

STANDARD FEATURES

- MODEL NUMBER IS RC-WC
- OVERALL WIDTH IS: 2 1/4"
- OVERALL LENGTH IS: 11 1/4"
- OVERALL HEIGHT IS: 3 5/8"
- 8 MAGNETS TOTAL (4 EACH SIDE)
- MADE OF SHORE A 87 NYLON
- (2) $\varnothing 1/2$ " PICK-UP HOLES
- UNIT IS SAFETY ORANGE

SPECIAL FEATURES

NONE

APPROVAL

I, THE UNDERSIGNED, AGREE THAT THE PRODUCT AS REPRESENTED SATISFIES DESIGN AND DIMENSION REQUIREMENTS. I ALSO ACKNOWLEDGE MY DUTY TO CONFIRM PRODUCT AND INSTALLATION COMPLIANCE WITH ALL APPLICABLE FEDERAL, STATE AND LOCAL REGULATIONS AND STANDARDS.
ALL SPECIAL UNITS ARE NON-RETURNABLE
 As drawn As marked

Signed: _____ Date: _____

LEAD TIME WILL START UPON RECEIPT OF SIGNED APPROVAL DRAWING

DISTRIBUTOR'S NAME:		P.O.#
VESTIL MANUFACTURING		X
DRAWN BY: T. MOORE		DATE: 09/26/11
REFERENCE: X		SALES: X
QUOTED LEAD TIME: X		SCALE: 1:2
QUOTE # X		FILE NAME: 29-007-162