

RUBBER PUSH BUMPER - RPB-2

APPROX WEIGHT: 38.31 lbs.
 DOES NOT INCLUDE WEIGHT OF POWER OR PACKAGING!!!

*** ANY ADDITIONS, DELETIONS, OR OMISSIONS MUST BE CORRECTED ON THIS DRAWING AS THIS DRAWING WILL BE CONSIDERED ALL INCLUSIVE ***

ALL GRAPHICS PROVIDED ARE FOR REFERENCE ONLY. IF CERTAIN DIMENSIONS ARE CRITICAL PLEASE VERIFY THOSE DIMENSIONS WITH YOUR SALESPERSON

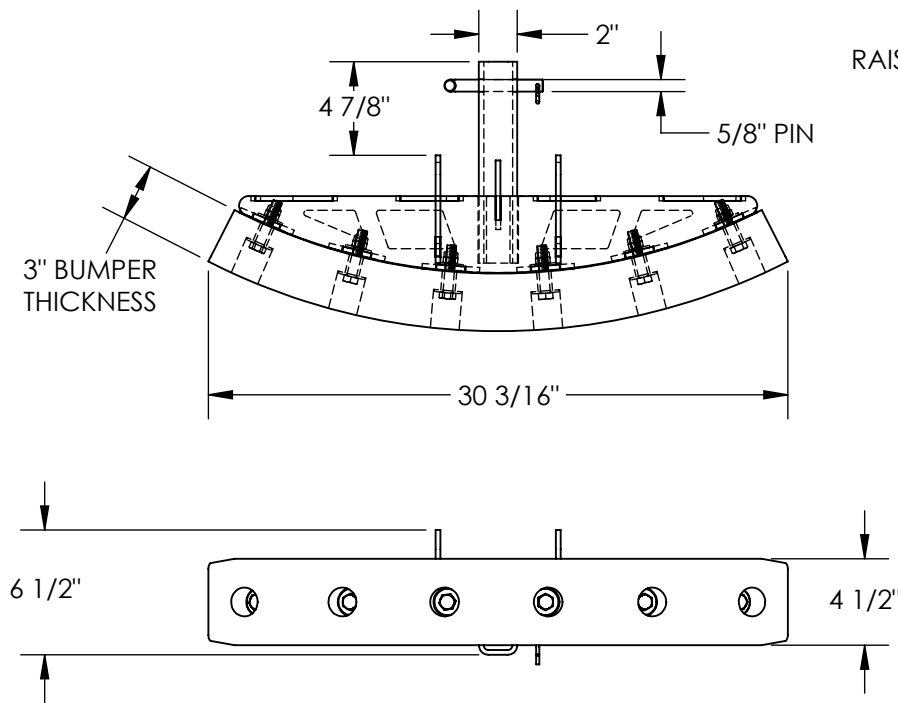

RAISED CARRY HANDLES

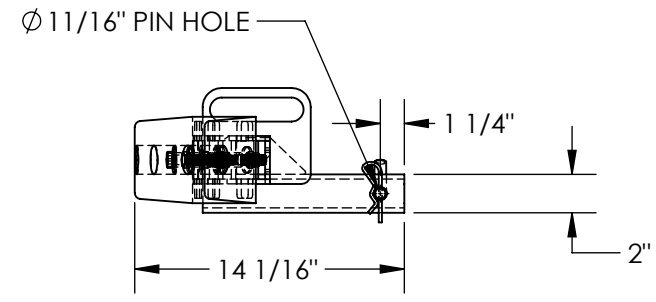
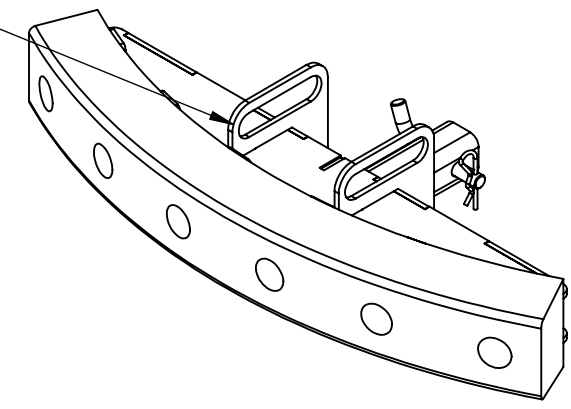

STANDARD FEATURES

- MODEL NUMBER IS RPB-2
- OVERALL WIDTH IS 30 3/16"
- OVERALL LENGTH IS 14 1/16"
- OVERALL HEIGHT IS 6 1/2"
- USABLE HEIGHT IS 4 1/2"
- FITS IN 2" RECEIVER
- DURABLE BAKED IN POWDER COAT YELLOW FINISH
- STEEL FRAME WITH BLACK RUBBER BUMPER
- BUMPER HAS DUROMETER READING OF 80 +/- 5
- TENSIL 950-1050 PSI
- IMPACT RECOVERY 95%

SPECIAL FEATURES

NONE

DIMENSION TOLERANCE $\pm 1/4$ "

APPROVAL	I, THE UNDERSIGNED, AGREE THAT THE PRODUCT AS REPRESENTED SATISFIES DESIGN AND DIMENSION REQUIREMENTS. I ALSO ACKNOWLEDGE MY DUTY TO CONFIRM PRODUCT AND INSTALLATION COMPLIANCE WITH ALL APPLICABLE FEDERAL, STATE AND LOCAL REGULATIONS AND STANDARDS.	
	UNITS REQUIRING APPROVAL DRAWINGS OR MODIFIED ARE NON-RETURNABLE	
	[] As drawn [] As marked	
Signed: _____		Date: _____
Printed Name: _____		
LEAD TIME WILL START UPON RECEIPT OF SIGNED APPROVAL DRAWING		

DISTRIBUTOR'S NAME:		P.O.#
VESTIL MANUFACTURING		X
DRAWN BY: JWW		W.O.#
DATE: 9/11/2020		X
REFERENCE: X	SCALE: 1:10	SALES: X
QUOTED LEAD TIME: X	QUOTE #	FILE NAME:
	X	08-007-460