

OVERHEAD SELF DUMPING BIN - SDB-200-6

APPROX WEIGHT: 890 lbs.
 DOES NOT INCLUDE WEIGHT OF POWER OR PACKAGING!!!

*** ANY ADDITIONS, DELETIONS, OR OMISSIONS MUST BE CORRECTED ON THIS DRAWING AS THIS DRAWING WILL BE CONSIDERED ALL INCLUSIVE ***

ALL GRAPHICS PROVIDED ARE FOR REFERENCE ONLY. IF CERTAIN DIMENSIONS ARE CRITICAL PLEASE VERIFY THOSE DIMENSIONS WITH YOUR SALESPERSON

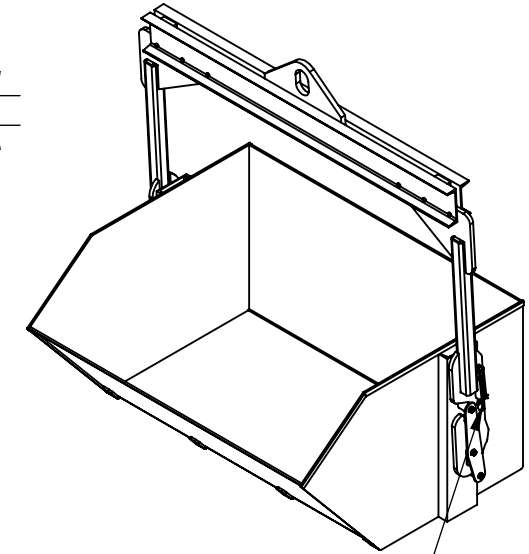
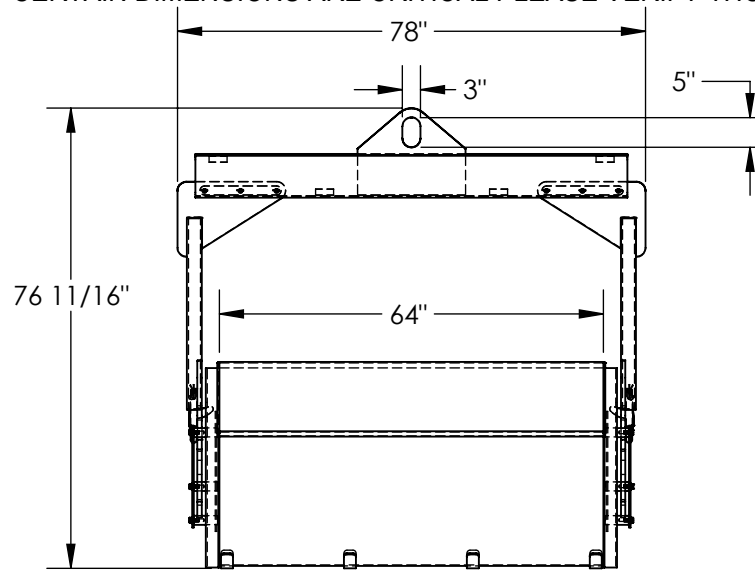
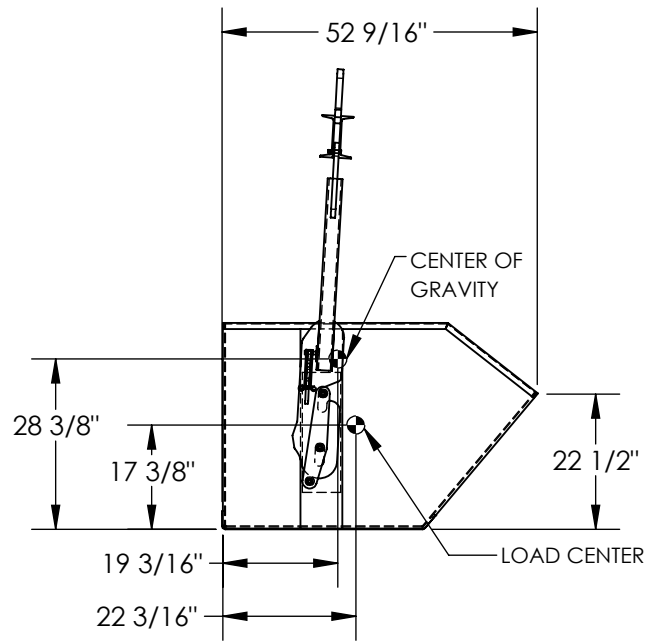

SAFETY LOCKS ON BOTH SIDES TO KEEP LIFTING BEAM UPRIGHT

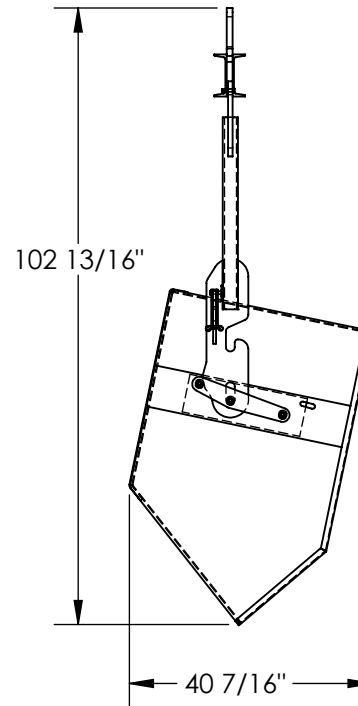

DIMENSION TOLERANCE ± 1/4"

STANDARD FEATURES

MODEL NUMBER IS SDB-200-6
 OVERALL WIDTH IS 78"
 USABLE WIDTH IS 64"
 OVERALL LENGTH IS 52 9/16"
 OVERALL HEIGHT IS 76 11/16"
 MAX CAPACITY IS 6,000 LB.
 VOLUME CAPACITY IS 2 CU. YRDS.
 HOPPER AND LIFTING BEAM IS DURABLE BAKED IN POWDER COAT BLUE FINISH WITH YELLOW UPRIGHTS

SPECIAL FEATURES

NONE

APPROVAL

I, THE UNDERSIGNED, AGREE THAT THE PRODUCT AS REPRESENTED SATISFIES DESIGN AND DIMENSION REQUIREMENTS. I ALSO ACKNOWLEDGE MY DUTY TO CONFIRM PRODUCT AND INSTALLATION COMPLIANCE WITH ALL APPLICABLE FEDERAL, STATE AND LOCAL REGULATIONS AND STANDARDS.
UNITS REQUIRING APPROVAL DRAWINGS OR MODIFIED ARE NON-RETURNABLE

As drawn As marked

Signed: _____ Date: _____

Printed Name: _____

LEAD TIME WILL START UPON RECEIPT OF SIGNED APPROVAL DRAWING

DISTRIBUTOR'S NAME:		P.O.#
VESTIL MANUFACTURING		X
DRAWN BY:	DATE:	W.O.#
JWW	3/16/2022	X
REFERENCE:	SCALE:	SALES:
X	1:32	X
QUOTED LEAD TIME:	QUOTE #	FILE NAME:
X	X	37-007-190