

# 2-SHELF STOCKPICKER TRUCK - SPA2-2236

APPROX WEIGHT: 76.91 lbs.  
 DOES NOT INCLUDE WEIGHT OF POWER OR PACKAGING!!!

\*\*\* ANY ADDITIONS, DELETIONS, OR OMISSIONS MUST BE CORRECTED ON THIS DRAWING AS THIS DRAWING WILL BE CONSIDERED ALL INCLUSIVE \*\*\*

ALL GRAPHICS PROVIDED ARE FOR REFERENCE ONLY. IF CERTAIN DIMENSIONS ARE CRITICAL PLEASE VERIFY THOSE DIMENSIONS WITH YOUR SALESPERSON

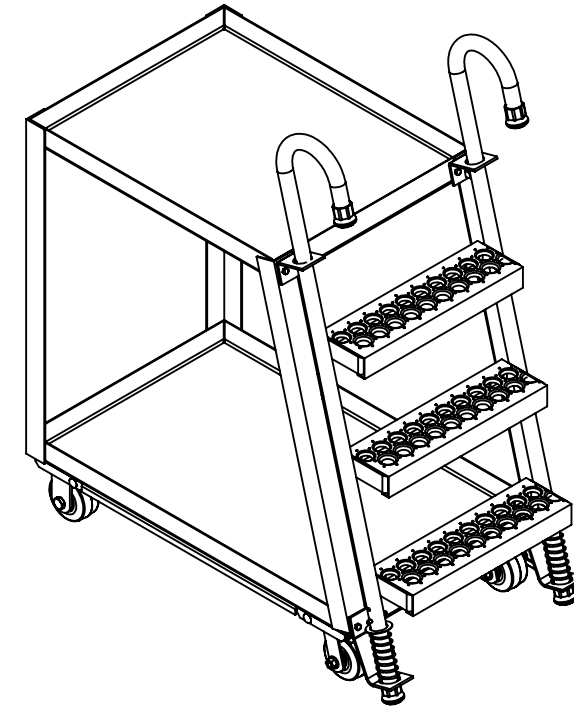
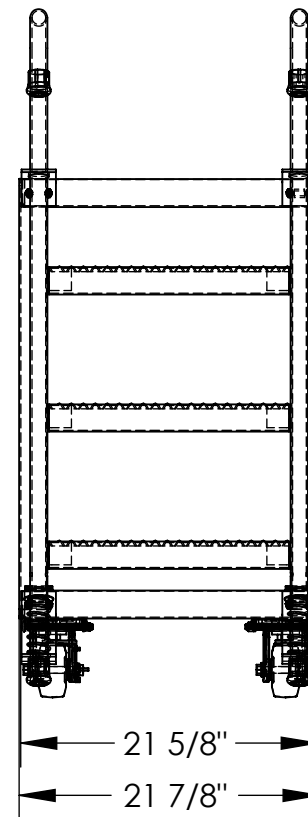
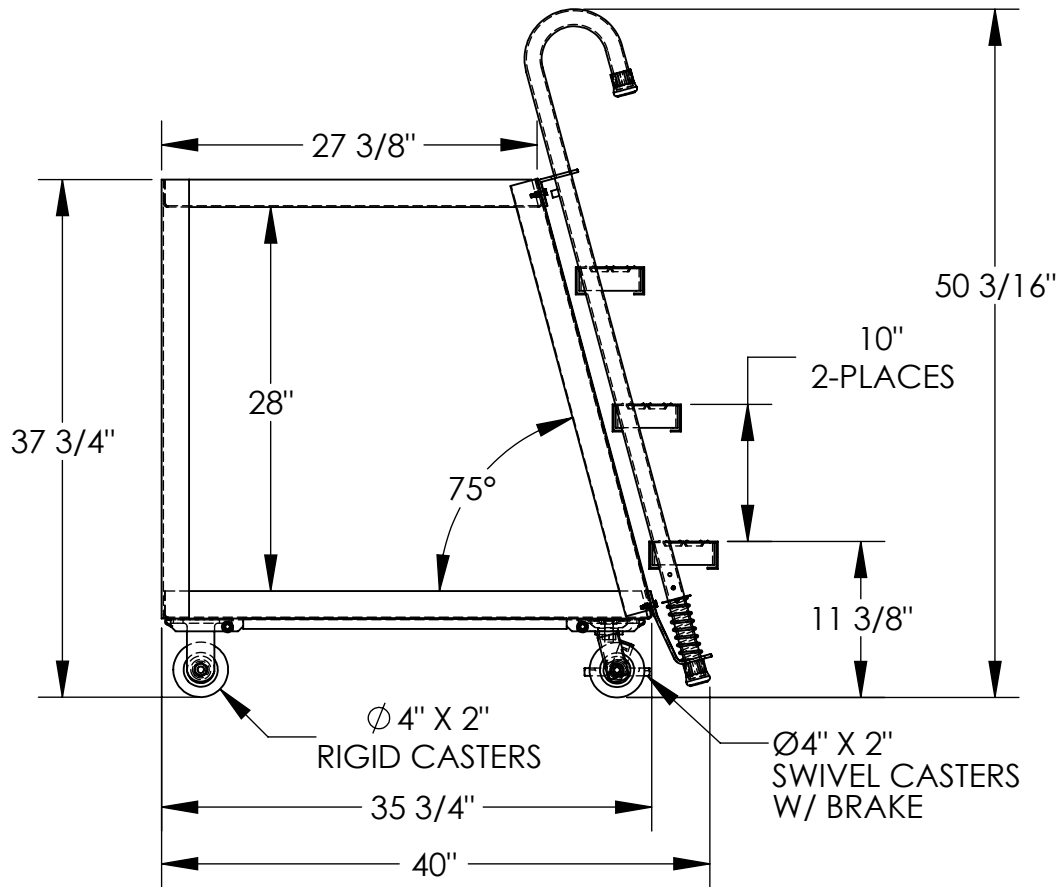

3D SHOWN FOR REFERENCE ONLY

DIMENSION TOLERANCE  $\pm 1/4"$

## STANDARD FEATURES

- MODEL NUMBER IS SPA2-2236
- CAPACITY: 660 LBS. TOTAL  
(330 LBS. PER SHELF)
- OVERALL WIDTH IS 21 7/8"
- OVERALL LENGTH IS 40"
- OVERALL HEIGHT IS 50 3/16"
- BOTTOM SHELF SIZE: 21 5/8" X 35 3/4"
- TOP SHELF SIZE: 21 5/8" X 27 3/8"
- TOP SHELF HEIGHT: 37 3/4"
- SHELF CLEARANCE: 28"
- (2) 4X2 MOLD-ON-RUBBER SWIVEL  
CASTER WITH BRAKE
- (2) 4x2 MOLD-ON-RUBBER RIGID CASTER  
ALUMINUM FRAME CONSTRUCTION
- STEEL LADDER WITH DURABLE BAKED IN  
POWDER COATED SILVER FINISH
- LADDER CAPACITY IS 350 LBS

## SPECIAL FEATURES

NONE

APPROVAL

I, THE UNDERSIGNED, AGREE THAT THE PRODUCT AS REPRESENTED SATISFIES DESIGN AND DIMENSION REQUIREMENTS. I ALSO ACKNOWLEDGE MY DUTY TO CONFIRM PRODUCT AND INSTALLATION COMPLIANCE WITH ALL APPLICABLE FEDERAL, STATE AND LOCAL REGULATIONS AND STANDARDS.

**UNITS REQUIRING APPROVAL DRAWINGS OR MODIFIED ARE NON-RETURNABLE**

[ ] As drawn [ ] As marked

Signed: \_\_\_\_\_ Date: \_\_\_\_\_

Printed Name: \_\_\_\_\_

LEAD TIME WILL START UPON RECEIPT OF SIGNED APPROVAL DRAWING

DISTRIBUTOR'S NAME:		P.O.#
VESTIL MANUFACTURING		X
DRAWN BY: ND		W.O.#
DATE: 8/31/05		X
REFERENCE: X	SCALE: 1:14	SALES: X
QUOTED LEAD TIME: X	QUOTE #	FILE NAME:
	X	32-007-007