

3-SHELF STOCKPICKER TRUCK - SPA3-2236

APPROX WEIGHT: 84.53 lbs.
DOES NOT INCLUDE WEIGHT OF POWER OR PACKAGING!!!

*** ANY ADDITIONS, DELETIONS, OR OMISSIONS MUST BE CORRECTED ON THIS DRAWING AS THIS DRAWING WILL BE CONSIDERED ALL INCLUSIVE ***

ALL GRAPHICS PROVIDED ARE FOR REFERENCE ONLY. IF CERTAIN DIMENSIONS ARE CRITICAL PLEASE VERIFY THOSE DIMENSIONS WITH YOUR SALESPERSON

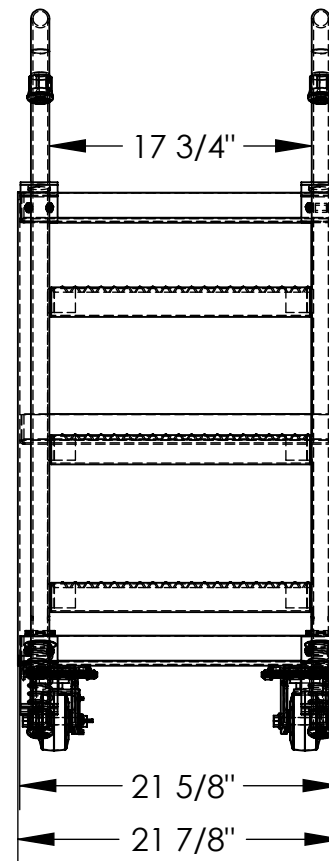
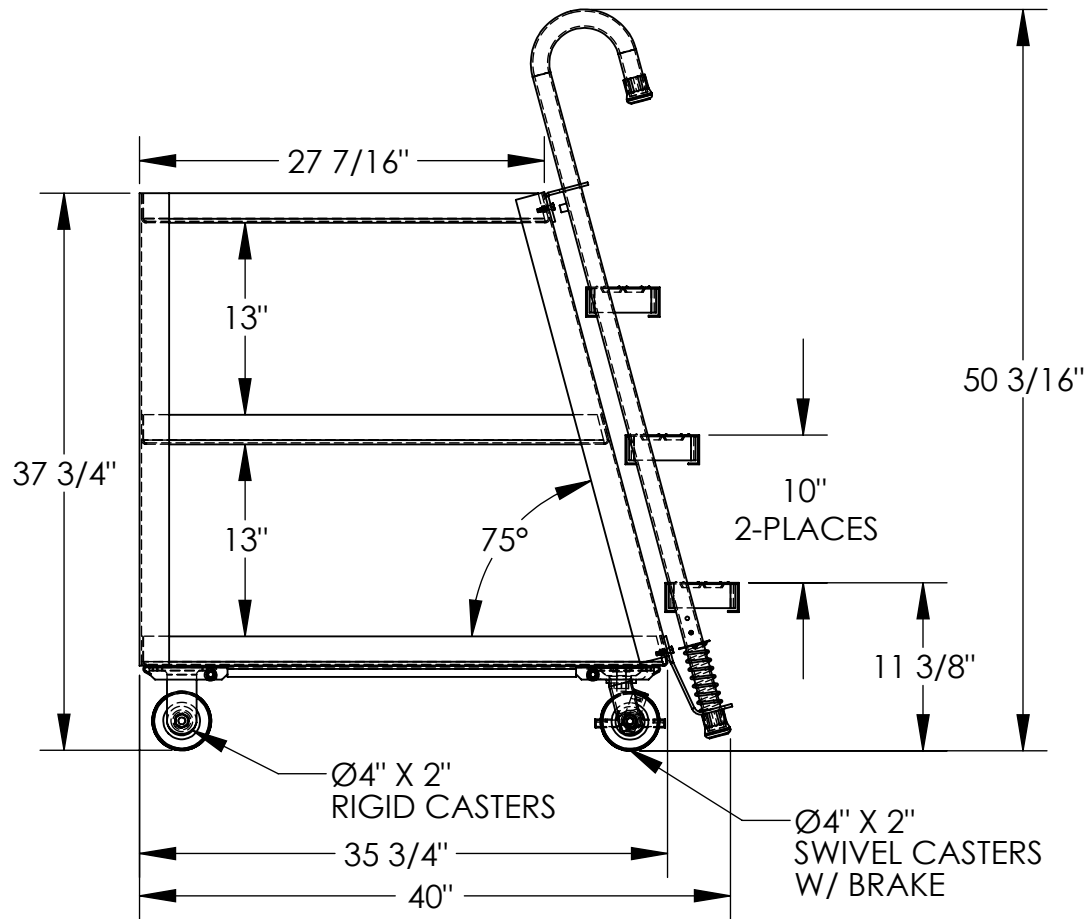

3D SHOWN FOR REFERENCE ONLY

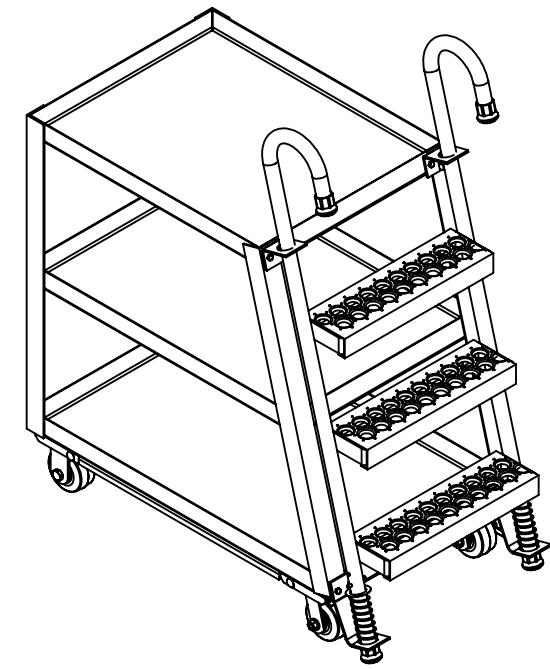

DIMENSION TOLERANCE ± 1/4"

STANDARD FEATURES

- MODEL NUMBER IS SPA3-2236
- CAPACITY: 1,000 LBS. (330 LBS. PER SHELF)
- OVERALL WIDTH IS 21 7/8"
- OVERALL LENGTH IS 40"
- OVERALL HEIGHT IS 50 3/16"
- BOTTOM SHELF SIZE: 21 5/8" X 35 3/4"
- TOP SHELF SIZE: 21 5/8" X 27 7/16"
- TOP SHELF HEIGHT: 37 3/4"
- SHELF CLEARANCE: 13"
- (2) 4X2 MOLD-ON-RUBBER SWIVEL CASTER WITH BRAKE
- (2) 4x2 MOLD-ON-RUBBER RIGID CASTER
- ALUMINUM FRAME CONSTRUCTION
- STEEL LADDER WITH DURABLE BAKED IN POWDER COATED SILVER FINISH
- LADDER CAPACITY IS 350 LBS

SPECIAL FEATURES

NONE

APPROVAL

I, THE UNDERSIGNED, AGREE THAT THE PRODUCT AS REPRESENTED SATISFIES DESIGN AND DIMENSION REQUIREMENTS. I ALSO ACKNOWLEDGE MY DUTY TO CONFIRM PRODUCT AND INSTALLATION COMPLIANCE WITH ALL APPLICABLE FEDERAL, STATE AND LOCAL REGULATIONS AND STANDARDS.

UNITS REQUIRING APPROVAL DRAWINGS OR MODIFIED ARE NON-RETURNABLE

[] As drawn [] As marked

Signed: _____ Date: _____

Printed Name: _____

LEAD TIME WILL START UPON RECEIPT OF SIGNED APPROVAL DRAWING

DISTRIBUTOR'S NAME:		P.O.#
VESTIL MANUFACTURING		X
DRAWN BY: NHD		W.O.#
DATE: 08/25/2017		X
REFERENCE: X	SCALE: 1:13	SALES: X
QUOTED LEAD TIME: X	QUOTE #	FILE NAME:
	X	32-007-041