

HANDRAIL KIT - SPN-2-YL-HR-RF

APPROX WEIGHT: 36.55 lbs.
 DOES NOT INCLUDE WEIGHT OF POWER OR PACKAGING!!!

*** ANY ADDITIONS, DELETIONS, OR OMISSIONS MUST BE CORRECTED ON THIS DRAWING AS THIS DRAWING WILL BE CONSIDERED ALL INCLUSIVE ***

ALL GRAPHICS PROVIDED ARE FOR REFERENCE ONLY. IF CERTAIN DIMENSIONS ARE CRITICAL PLEASE VERIFY THOSE DIMENSIONS WITH YOUR SALESPERSON

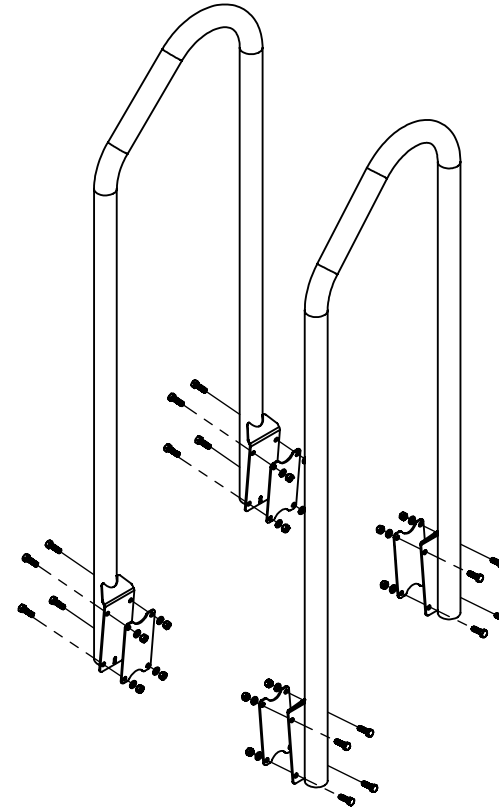
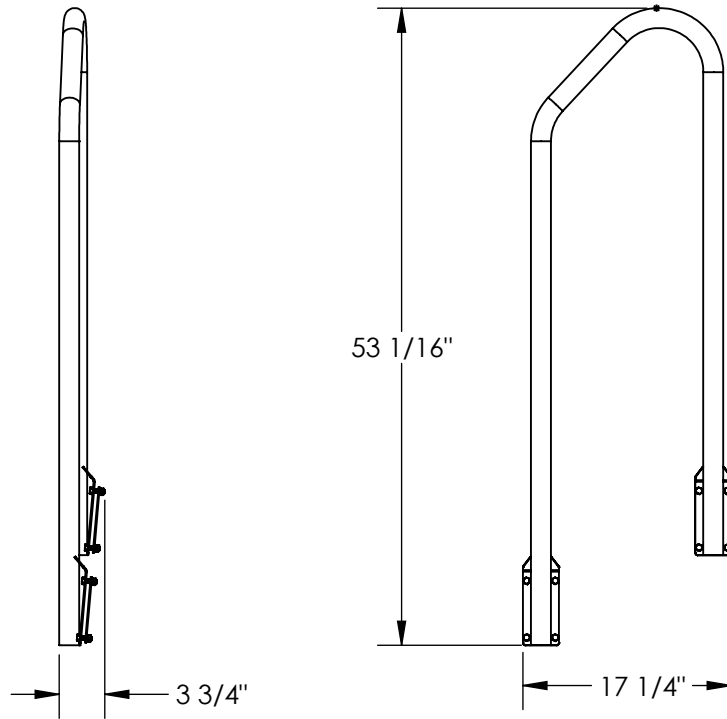

DIMENSION TOLERANCE $\pm 1/4"$

STANDARD FEATURES

MODEL NUMBER IS SPN-2-YL-HR-RF
 HANDRAIL KIT FOR SPN-2
 INCLUDES (2) HANDRAILS, BOLTS, LOCK WASHERS, NUTS,
 AND SUPPORT BRACKETS
 WILL NEED TO DRILL HOLES TO MOUNT TO SPN-2
 DURABLE BAKED IN POWDER COATED YELLOW FINISH

SPECIAL FEATURES

NONE

APPROVAL

I, THE UNDERSIGNED, AGREE THAT THE PRODUCT AS REPRESENTED SATISFIES DESIGN AND DIMENSION REQUIREMENTS. I ALSO ACKNOWLEDGE MY DUTY TO CONFIRM PRODUCT AND INSTALLATION COMPLIANCE WITH ALL APPLICABLE FEDERAL, STATE AND LOCAL REGULATIONS AND STANDARDS.
UNITS REQUIRING APPROVAL DRAWINGS OR MODIFIED ARE NON-RETURNABLE

As drawn As marked

Signed: _____ Date: _____

Printed Name: _____

LEAD TIME WILL START UPON RECEIPT OF SIGNED APPROVAL DRAWING

DISTRIBUTOR'S NAME:		P.O.#
VESTIL MANUFACTURING		X
DRAWN BY: KGH		DATE: 11/13/2018
REFERENCE: X		SCALE: 1:12
QUOTED LEAD TIME: X		QUOTE # X
		SALES: X
		FILE NAME: 14-007-329