

NESTABLE STEP STOOL W/ HANDRAIL - SPN-2-YL-HR

APPROX WEIGHT: 58 lbs.
DOES NOT INCLUDE WEIGHT OF POWER OR PACKAGING!!!

*** ANY ADDITIONS, DELETIONS, OR OMISSIONS MUST BE CORRECTED ON THIS DRAWING AS THIS DRAWING WILL BE CONSIDERED ALL INCLUSIVE ***
ALL GRAPHICS PROVIDED ARE FOR REFERENCE ONLY. IF CERTAIN DIMENSIONS ARE CRITICAL PLEASE VERIFY THOSE DIMENSIONS WITH YOUR SALESPERSON

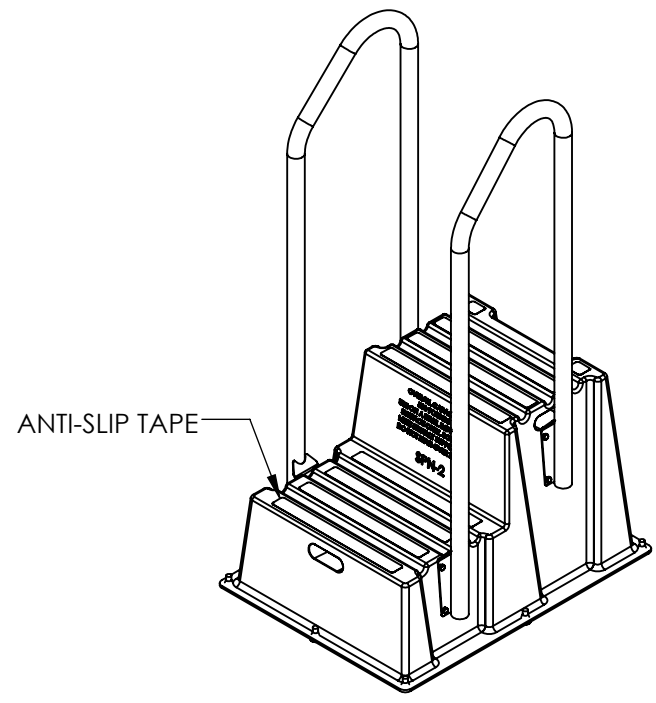
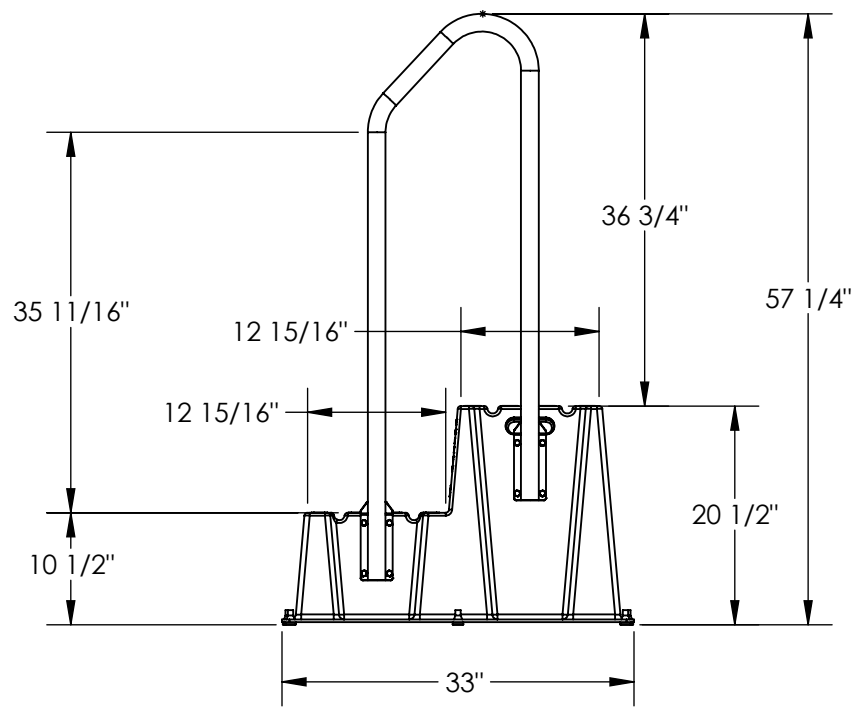
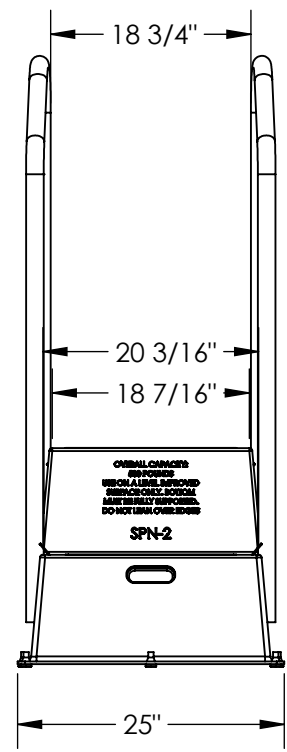

STANDARD FEATURES

- MODEL NUMBER IS SPN-2-YL-HR
- OVERALL WIDTH IS 25"
- OVERALL LENGTH IS 33"
- OVERALL HEIGHT IS 57 1/4"
- FIRST STEP HEIGHT IS 10 1/2"
- SECOND STEP HEIGHT IS 20 1/2"
- FIRST STEP IS 20 3/16" X 12 15/16"
- SECOND STEP IS 18 7/16" X 12 15/16"
- MAX CAPACITY IS 500 LBS
- MADE OF MEDIUM DENSITY POLYETHYLENE
- COMES WITH ANTI-SLIP TAPE ON STEP SURFACE
- INCLUDES BOLT-ON HANDRAIL
- COLOR IS SAFETY YELLOW

SPECIAL FEATURES

NONE

DIMENSION TOLERANCE ± 1/4"

APPROVAL	I, THE UNDERSIGNED, AGREE THAT THE PRODUCT AS REPRESENTED SATISFIES DESIGN AND DIMENSION REQUIREMENTS. I ALSO ACKNOWLEDGE MY DUTY TO CONFIRM PRODUCT AND INSTALLATION COMPLIANCE WITH ALL APPLICABLE FEDERAL, STATE AND LOCAL REGULATIONS AND STANDARDS.	
	ANY MODIFIED UNITS ARE NON-RETURNABLE	
	[] As drawn [] As marked	
	Signed: _____ Date: _____	
Printed Name: _____		
LEAD TIME WILL START UPON RECEIPT OF SIGNED APPROVAL DRAWING		

FOR INTERNAL USE ONLY PROJECT SIGN OFF	
SALES	
ENG.	
FAB.	
POWER	

DISTRIBUTOR'S NAME:		P.O.#
VESTIL MANUFACTURING		X
DRAWN BY: KGH		W.O.#
DATE: 11/13/2018		X
REFERENCE: X	SCALE: 1:18	SALES: X
QUOTED LEAD TIME: X	QUOTE #	FILE NAME:
	X	14-007-320