

SPN 3 STEP YELLOW ALL OPTIONS KIT - SPN-3-YL-AOK

APPROX WEIGHT: 53 lbs.
DOES NOT INCLUDE WEIGHT OF POWER OR PACKAGING!!!

*** ANY ADDITIONS, DELETIONS, OR OMISSIONS MUST BE CORRECTED ON THIS DRAWING AS THIS DRAWING WILL BE CONSIDERED ALL INCLUSIVE ***

ALL GRAPHICS PROVIDED ARE FOR REFERENCE ONLY. IF CERTAIN DIMENSIONS ARE CRITICAL PLEASE VERIFY THOSE DIMENSIONS WITH YOUR SALESPERSON

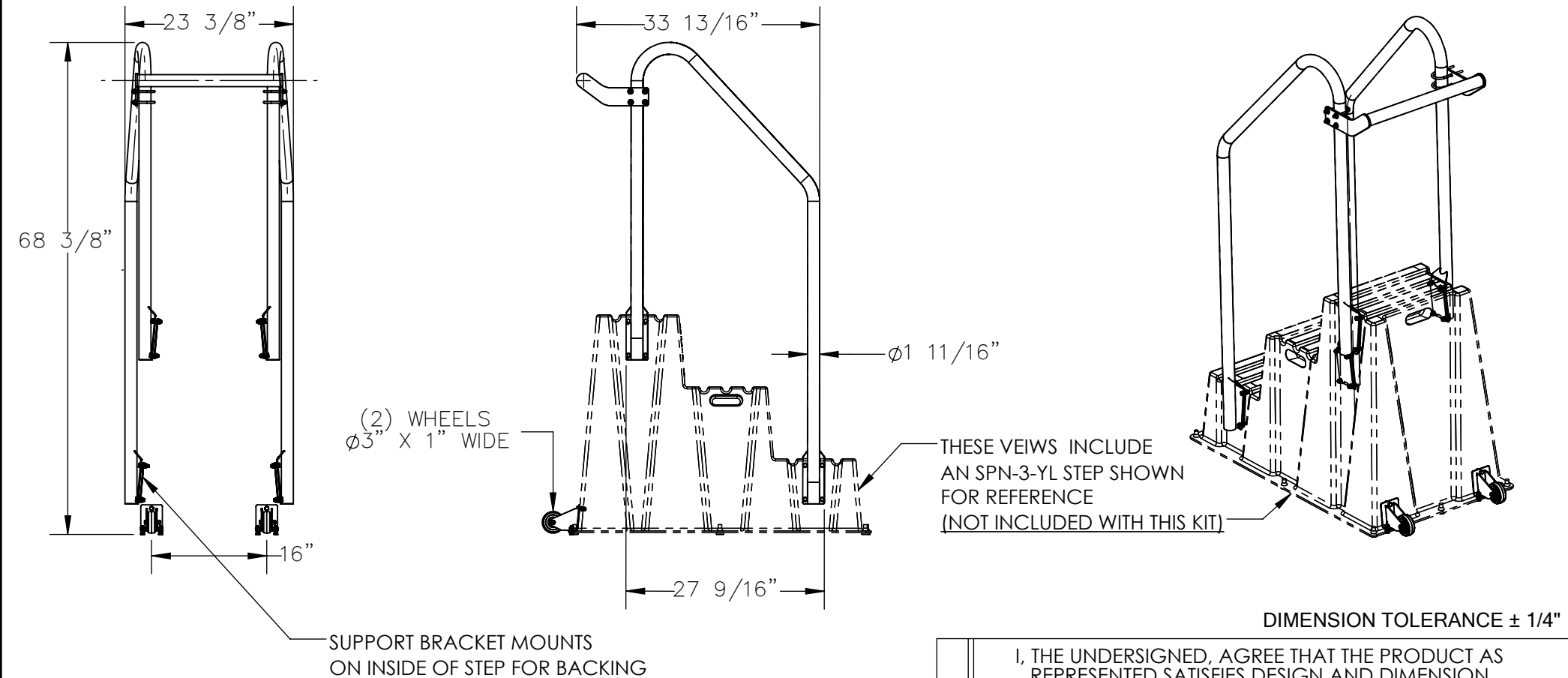

STANDARD FEATURES

- MODEL NUMBER IS SPN-3-YL-AOK
- OVERALL WIDTH IS 23 3/8"
- OVERALL HEIGHT IS 68 3/8"
- OVERALL LENGTH IS 33 13/16"
- INCLUDES (2) CASTERS WITH BRACKETS, BOLTS, AND NUTS
- INCLUDES (2) HANDRAILS WITH BOLTS, LOCK WASHERS, NUTS, AND SUPPORT BRACKETS
- INCLUDES BACK RAIL, U-BOLTS, WASHERS, AND NUTS
- WILL NEED TO DRILL HOLES IN SPN TO MOUNT ADD ON OPTIONS
- DURABLE BAKED IN POWDER COATED YELLOW FINISH

SPECIAL FEATURES

NONE

APPROVAL	I, THE UNDERSIGNED, AGREE THAT THE PRODUCT AS REPRESENTED SATISFIES DESIGN AND DIMENSION REQUIREMENTS. I ALSO ACKNOWLEDGE MY DUTY TO CONFIRM PRODUCT AND INSTALLATION COMPLIANCE WITH ALL APPLICABLE FEDERAL, STATE AND LOCAL REGULATIONS AND STANDARDS.	
	UNITS REQUIRING APPROVAL DRAWINGS OR MODIFIED ARE NON-RETURNABLE	
	[] As drawn [] As marked	
	Signed: _____	Date: _____
Printed Name: _____		
LEAD TIME WILL START UPON RECEIPT OF SIGNED APPROVAL DRAWING		

DISTRIBUTOR'S NAME:		P.O.#
VESTIL MANUFACTURING		X
		W.O.#
DRAWN BY: MTS		X
DATE: 11/14/2024		SALES: X
REFERENCE: X	SCALE: 1:20	FILE NAME:
QUOTED LEAD TIME: X	QUOTE # X	14-007-359