

NESTABLE STEP STOOL W/ HANDRAILS & CASTERS - SPN-3-YL-HR-PO

APPROX WEIGHT: 77 lbs.
DOES NOT INCLUDE WEIGHT OF POWER OR PACKAGING!!!

*** ANY ADDITIONS, DELETIONS, OR OMISSIONS MUST BE CORRECTED ON THIS DRAWING AS THIS DRAWING WILL BE CONSIDERED ALL INCLUSIVE ***
ALL GRAPHICS PROVIDED ARE FOR REFERENCE ONLY. IF CERTAIN DIMENSIONS ARE CRITICAL PLEASE VERIFY THOSE DIMENSIONS WITH YOUR SALESPERSON

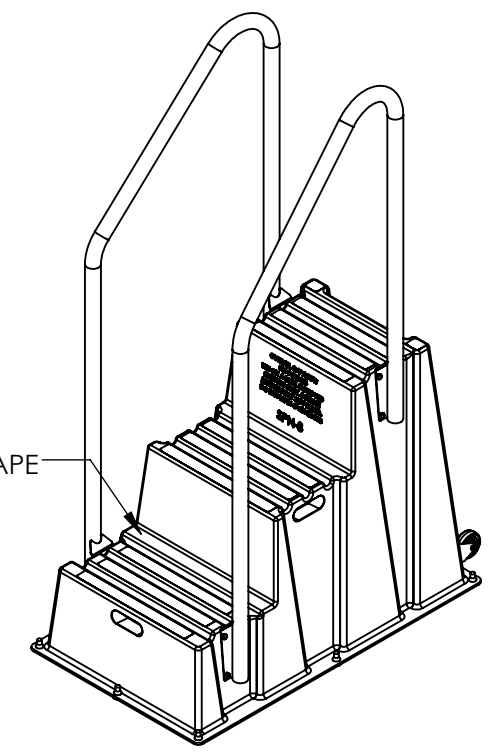
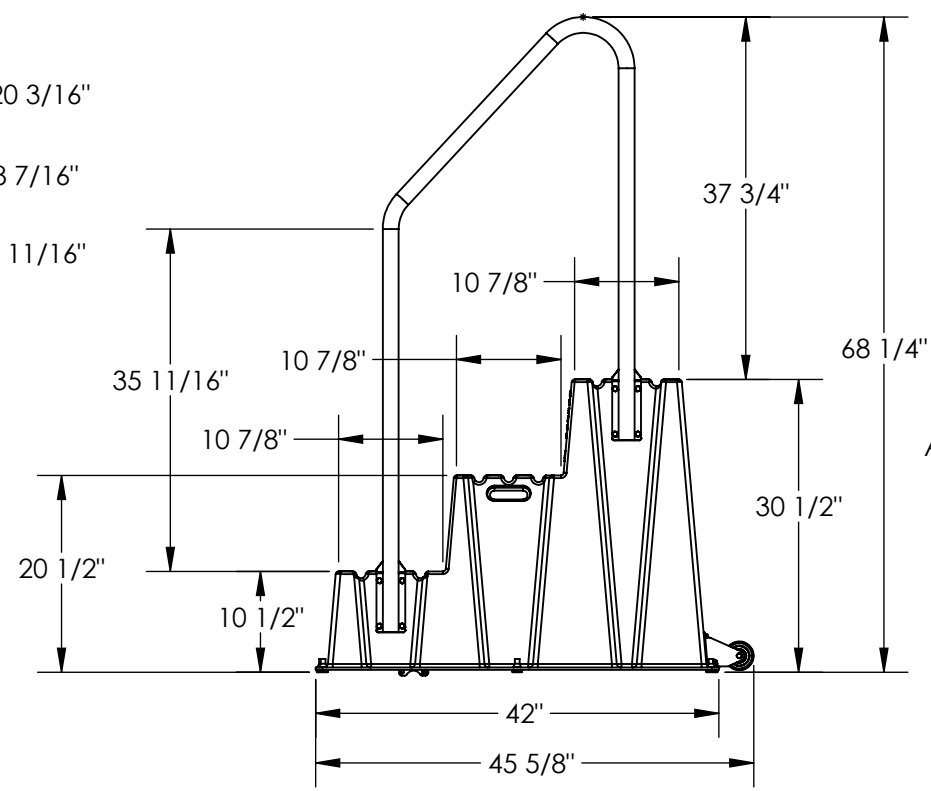
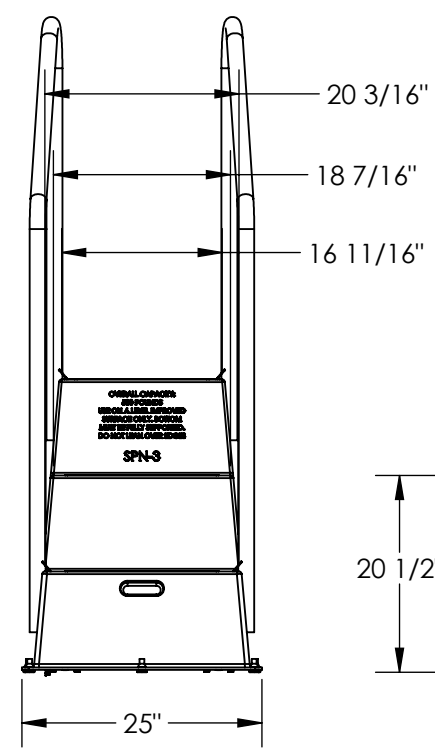

DIMENSION TOLERANCE ± 1/4"

STANDARD FEATURES

- MODEL NUMBER IS SPN-3-YL-HR-PO
- OVERALL WIDTH IS 25"
- OVERALL LENGTH IS 45 5/8"
- OVERALL HEIGHT IS 68 1/4"
- FIRST STEP HEIGHT IS 10 1/2"
- SECOND STEP HEIGHT IS 20 1/2"
- THIRD STEP HEIGHT IS 30 1/2"
- FIRST STEP IS 20 3/16" X 10 7/8"
- SECOND STEP IS 18 7/16" X 10 7/8"
- THIRD STEP IS 16 11/16" X 10 7/8"
- MAX CAPACITY IS 500 LBS.

MADE OF MEDIUM DENSITY POLYETHYLENE
COMES WITH ANTI-SLIP TAPE ON STEP SURFACE
INCLUDES BOLT-ON HANDRAILS & CASTERS
COLOR IS SAFETY YELLOW

SPECIAL FEATURES

NONE

APPROVAL

I, THE UNDERSIGNED, AGREE THAT THE PRODUCT AS REPRESENTED SATISFIES DESIGN AND DIMENSION REQUIREMENTS. I ALSO ACKNOWLEDGE MY DUTY TO CONFIRM PRODUCT AND INSTALLATION COMPLIANCE WITH ALL APPLICABLE FEDERAL, STATE AND LOCAL REGULATIONS AND STANDARDS.
UNITS REQUIRING APPROVAL DRAWINGS OR MODIFIED ARE NON-RETURNABLE

[] As drawn [] As marked

Signed: _____ Date: _____

Printed Name: _____

LEAD TIME WILL START UPON RECEIPT OF SIGNED APPROVAL DRAWING

DISTRIBUTOR'S NAME:		P.O.#
VESTIL MANUFACTURING		X
DRAWN BY: KGH		W.O.#
DATE: 11/13/2018		X
REFERENCE: X	SCALE: 1:20	SALES: X
QUOTED LEAD TIME: X	QUOTE #	FILE NAME:
	X	14-007-324