

# HI-FRAME STOCKPICKER TRUCK - SPS-HF-2852

APPROX WEIGHT: 223.45 lbs.  
 DOES NOT INCLUDE WEIGHT OF POWER OR PACKAGING!!!

\*\*\* ANY ADDITIONS, DELETIONS, OR OMISSIONS MUST BE CORRECTED ON THIS DRAWING AS THIS DRAWING WILL BE CONSIDERED ALL INCLUSIVE \*\*\*

ALL GRAPHICS PROVIDED ARE FOR REFERENCE ONLY. IF CERTAIN DIMENSIONS ARE CRITICAL PLEASE VERIFY THOSE DIMENSIONS WITH YOUR SALESPERSON

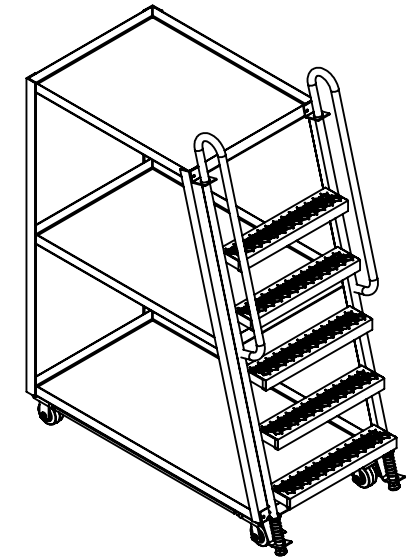
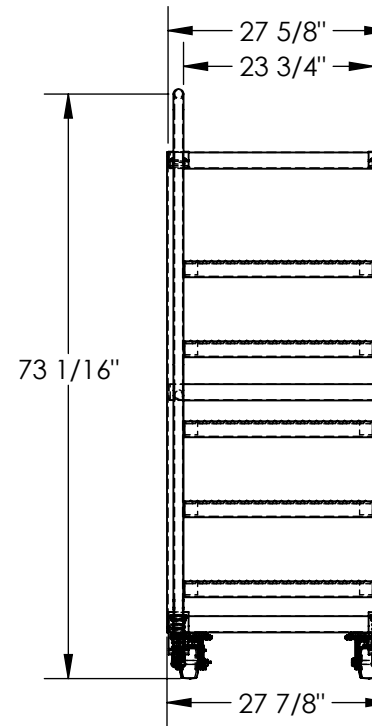
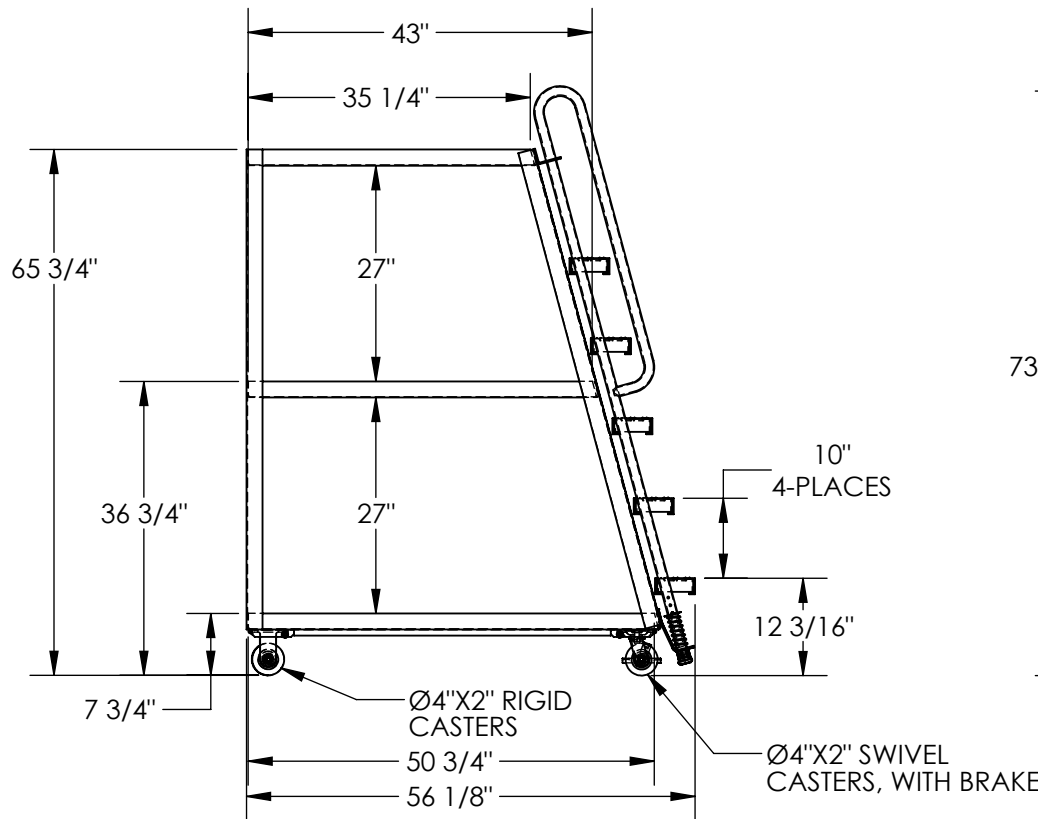

DIMENSION TOLERANCE ± 1/4"

## STANDARD FEATURES

- MODEL NUMBER IS SPS-HF-2852
- MAX CAPACITY PER SHELF IS 500 LBS.
- MAX CAPACITY TOTAL IS 1,000 LBS.
- OVERALL WIDTH IS 27 7/8"
- OVERALL LENGTH IS 56 1/8"
- OVERALL HEIGHT IS 73 1/16"
- TOP SHELF SIZE (USABLE) IS 27 1/2" X 35 1/4"
- MIDDLE SHELF SIZE (USABLE) IS 27 1/2" X 43"
- BOTTOM SHELF SIZE (USABLE) IS 27 1/2" X 50 3/4"
- SHELF CLEARANCE IS 27"
- DURABLE BAKED IN POWDER COATED BLUE FINISH
- (2) 4"X2" MOLD-ON -RUBBER RIGID CASTER
- (2) 4"X2" MOLD-ON-RUBBER SWIVEL CASTER WITH BRAKE
- LADDER CAPACITY IS 350 LBS.

## SPECIAL FEATURES

NONE

APPROVAL

I, THE UNDERSIGNED, AGREE THAT THE PRODUCT AS REPRESENTED SATISFIES DESIGN AND DIMENSION REQUIREMENTS. I ALSO ACKNOWLEDGE MY DUTY TO CONFIRM PRODUCT AND INSTALLATION COMPLIANCE WITH ALL APPLICABLE FEDERAL, STATE AND LOCAL REGULATIONS AND STANDARDS.  
**UNITS REQUIRING APPROVAL DRAWINGS OR MODIFIED ARE NON-RETURNABLE**

As drawn       As marked

Signed: \_\_\_\_\_ Date: \_\_\_\_\_

Printed Name: \_\_\_\_\_

LEAD TIME WILL START UPON RECEIPT OF SIGNED APPROVAL DRAWING

DISTRIBUTOR'S NAME:		P.O.#
VESTIL MANUFACTURING		X
DRAWN BY: CJC		W.O.#
DATE: 10/5/2015		X
REFERENCE: X	SCALE: 1:24	SALES: X
QUOTED LEAD TIME: X	QUOTE #	FILE NAME:
	X	32-007-025