

DOUBLE VERTICAL STORAGE RACK CART - SSRT-47-DRC-2500

APPROX WEIGHT: 510.74 lbs.
DOES NOT INCLUDE WEIGHT OF POWER OR PACKAGING!!!

*** ANY ADDITIONS, DELETIONS, OR OMISSIONS MUST BE CORRECTED ON THIS DRAWING AS THIS DRAWING WILL BE CONSIDERED ALL INCLUSIVE ***

ALL GRAPHICS PROVIDED ARE FOR REFERENCE ONLY. IF CERTAIN DIMENSIONS ARE CRITICAL PLEASE VERIFY THOSE DIMENSIONS WITH YOUR SALESPERSON

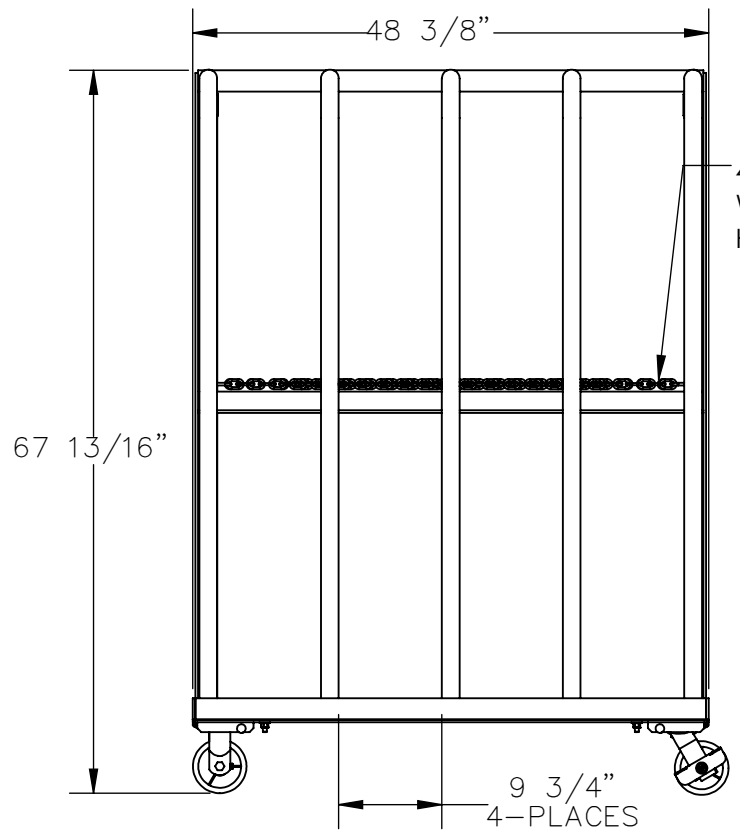
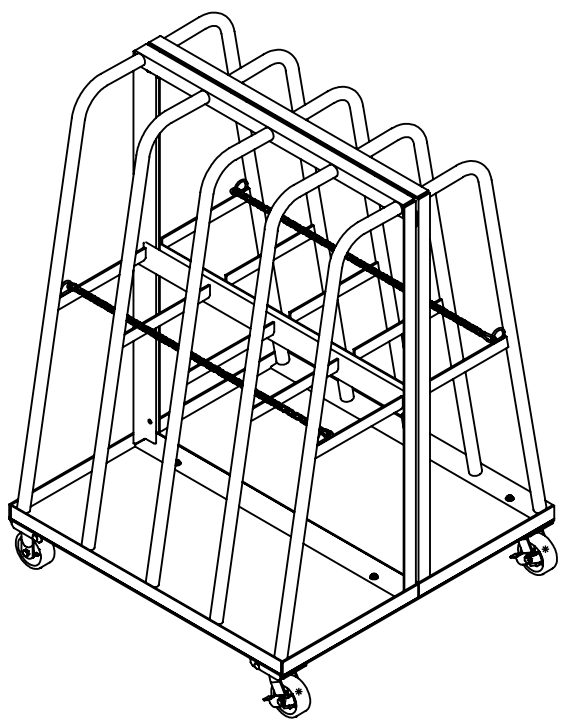

48" CHAIN
W/ SNAP
HOOKS

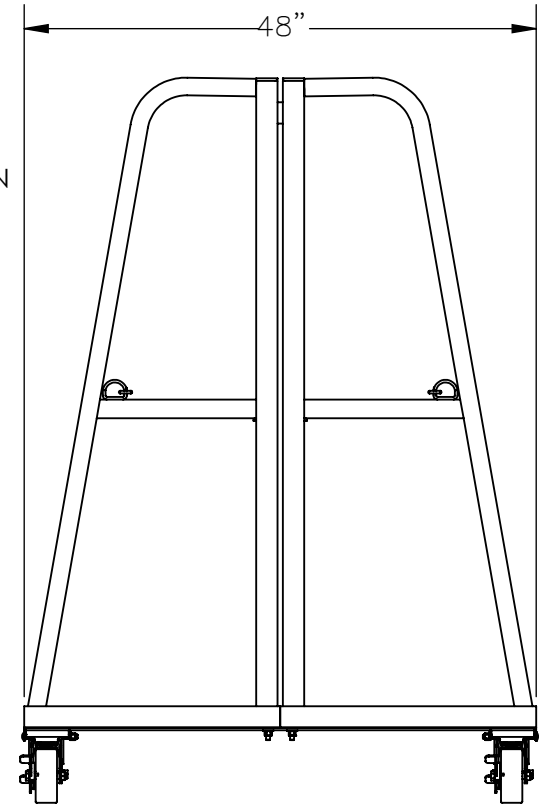

DIMENSION TOLERANCE ± 1/4"

STANDARD FEATURES

- MODEL #: SSRT-47-DRC-2500
- ASSEMBLY REQUIRED BY CUSTOMER
- STORAGE: 8 BAYS
- 9 3/4" OPENING BETWEEN DIVIDERS
- OVERALL CAPACITY: 2500 LBS.
- CAPACITY IS 750 LBS. PER BAY
- MAX LOAD HEIGHT: 10 FT.
- COLOR IS TOUGH BAKED IN POWDER COATED BLUE FINISH
- OVERALL HEIGHT: 67 13/16"
- OVERALL WIDTH: 48 3/8"
- OVERALL LENGTH: 48"
- 48" LG CHAIN W/ SNAP HOOKS AT EACH END
- ALL STEEL CONSTRUCTION
- INCLUDES TWO PU-5/2-S-SWB, SWIVEL CASTER W/BRAKE
- AND TWO PU-5/2-R, RIGID CASTERS

SPECIAL FEATURES

NONE

APPROVAL	I, THE UNDERSIGNED, AGREE THAT THE PRODUCT AS REPRESENTED SATISFIES DESIGN AND DIMENSION REQUIREMENTS. I ALSO ACKNOWLEDGE MY DUTY TO CONFIRM PRODUCT AND INSTALLATION COMPLIANCE WITH ALL APPLICABLE FEDERAL, STATE AND LOCAL REGULATIONS AND STANDARDS.	
	UNITS REQUIRING APPROVAL DRAWINGS OR MODIFIED ARE NON-RETURNABLE	
	[] As drawn [] As marked	
Signed: _____		Date: _____
Printed Name: _____		
<i>LEAD TIME WILL START UPON RECEIPT OF SIGNED APPROVAL DRAWING</i>		

DISTRIBUTOR'S NAME:		P.O.#
VESTIL MANUFACTURING		X
		W.O.#
DRAWN BY: T. HARKRADER		DATE: 07/28/21
REFERENCE: X		SALES: X
QUOTED LEAD TIME: X		SCALE: 1:32
QUOTE # X		FILE NAME:
		33-007-409