

# VERTICAL STORAGE RACK - SSRT-47-HP-WB-2

APPROX WEIGHT: 168.06 lbs.  
 DOES NOT INCLUDE WEIGHT OF POWER OR PACKAGING!!!

\*\*\* ANY ADDITIONS, DELETIONS, OR OMISSIONS MUST BE CORRECTED ON THIS DRAWING AS THIS DRAWING WILL BE CONSIDERED ALL INCLUSIVE \*\*\*

ALL GRAPHICS PROVIDED ARE FOR REFERENCE ONLY. IF CERTAIN DIMENSIONS ARE CRITICAL PLEASE VERIFY THOSE DIMENSIONS WITH YOUR SALESPERSON

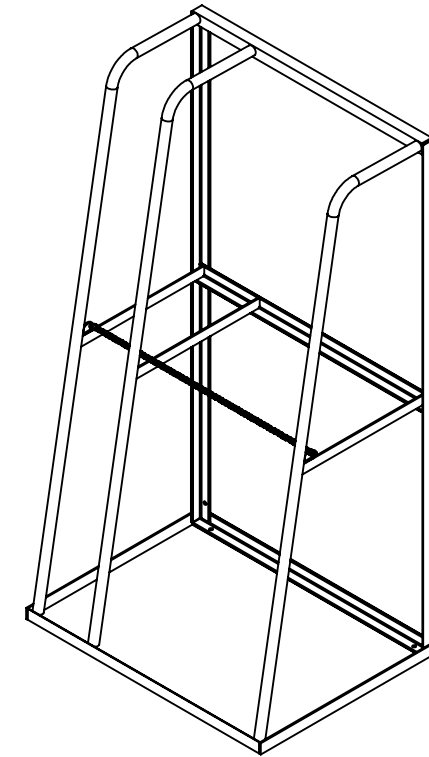
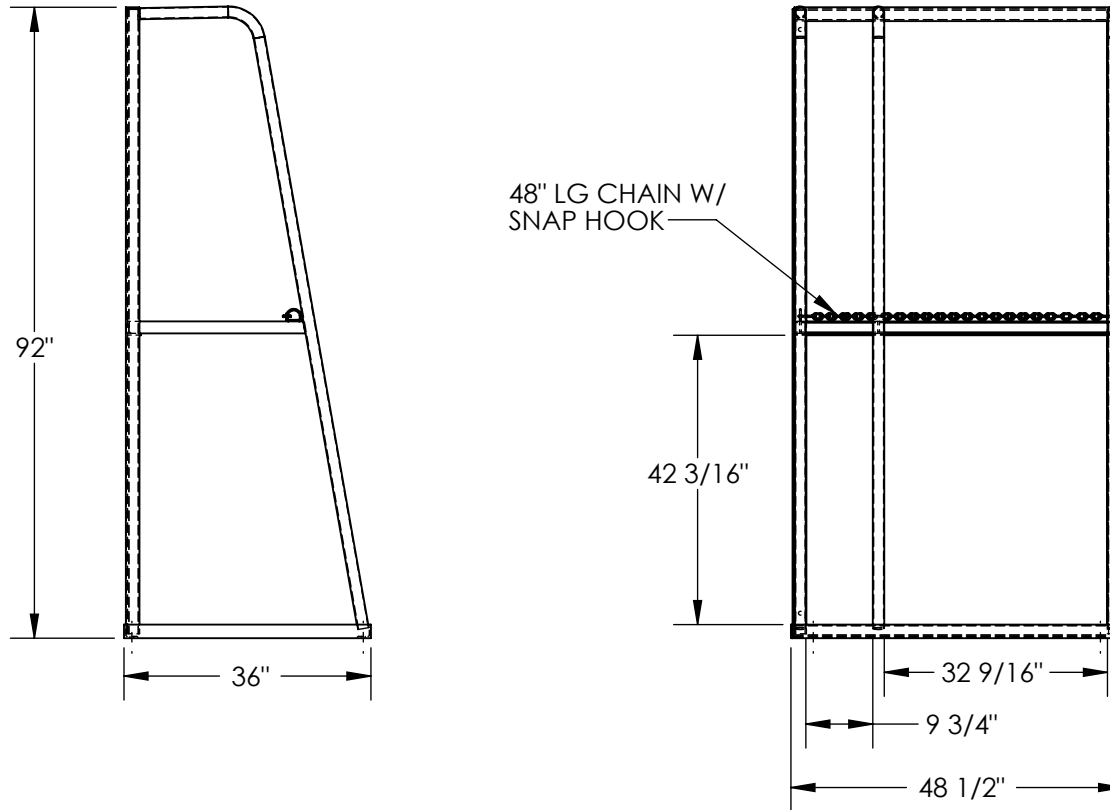

DIMENSION TOLERANCE 1/4"

I, THE UNDERSIGNED, AGREE THAT THE PRODUCT AS REPRESENTED SATISFIES DESIGN AND DIMENSION REQUIREMENTS. I ALSO ACKNOWLEDGE MY DUTY TO CONFIRM PRODUCT AND INSTALLATION COMPLIANCE WITH ALL APPLICABLE FEDERAL, STATE AND LOCAL REGULATIONS AND STANDARDS.

**ANY MODIFIED UNITS ARE NON-RETURNABLE**

As drawn       As marked

Signed: \_\_\_\_\_ Date: \_\_\_\_\_

Printed Name: \_\_\_\_\_

LEAD TIME WILL START UPON RECEIPT OF SIGNED APPROVAL DRAWING

APPROVAL

## STANDARD FEATURES

- MODEL NUMBER IS: SSRT-47-HP-WB-2
- CAPACITY IS: 1,500 LBS. PER BAY
- OVERALL WIDTH IS: 48 1/2"
- OVERALL DEPTH IS: 36"
- OVERALL HEIGHT IS: 92"
- 2 STORAGE BAYS; 9 3/4" AND 32 9/16" BETWEEN BAYS
- SUPPLIED WITH LAG DOWN POINTS WITH Ø9/16" HOLES
- ALL STEEL CONSTRUCTION
- 48" LG CHAIN W/ SNAP HOOKS AT EACH END
- TOUGH BAKED IN POWDER COATED BLUE FINISH

## SPECIAL FEATURES

NONE

FOR INTERNAL USE ONLY  
 PROJECT SIGN OFF

SALES	
ENG.	
FAB.	
POWER	

DISTRIBUTOR'S NAME:		P.O.#
VESTIL MANUFACTURING		X
DRAWN BY: JWW	DATE: 7/27/2020	W.O.#
REFERENCE: X	SCALE: 1:28	X
QUOTED LEAD TIME: X	QUOTE #	FILE NAME:
	X	31-007-319