

VERTICAL STORAGE RACK - SSRT-47-HP-WB-3

APPROX WEIGHT: 168.06 lbs.
DOES NOT INCLUDE WEIGHT OF POWER OR PACKAGING!!!

*** ANY ADDITIONS, DELETIONS, OR OMISSIONS MUST BE CORRECTED ON THIS DRAWING AS THIS DRAWING WILL BE CONSIDERED ALL INCLUSIVE ***

ALL GRAPHICS PROVIDED ARE FOR REFERENCE ONLY. IF CERTAIN DIMENSIONS ARE CRITICAL PLEASE VERIFY THOSE DIMENSIONS WITH YOUR SALESPERSON

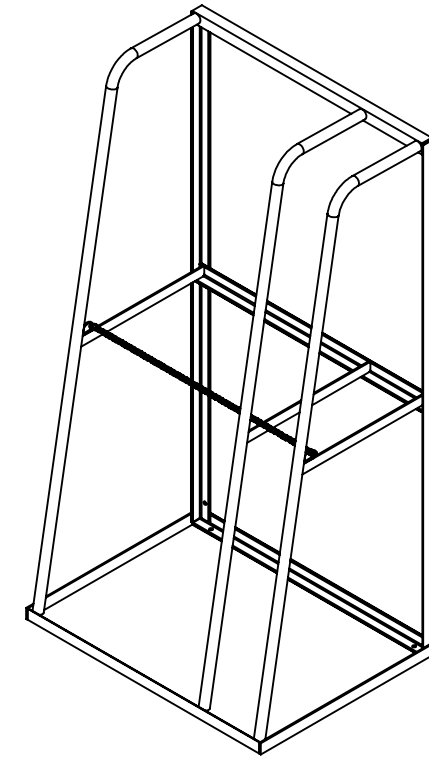
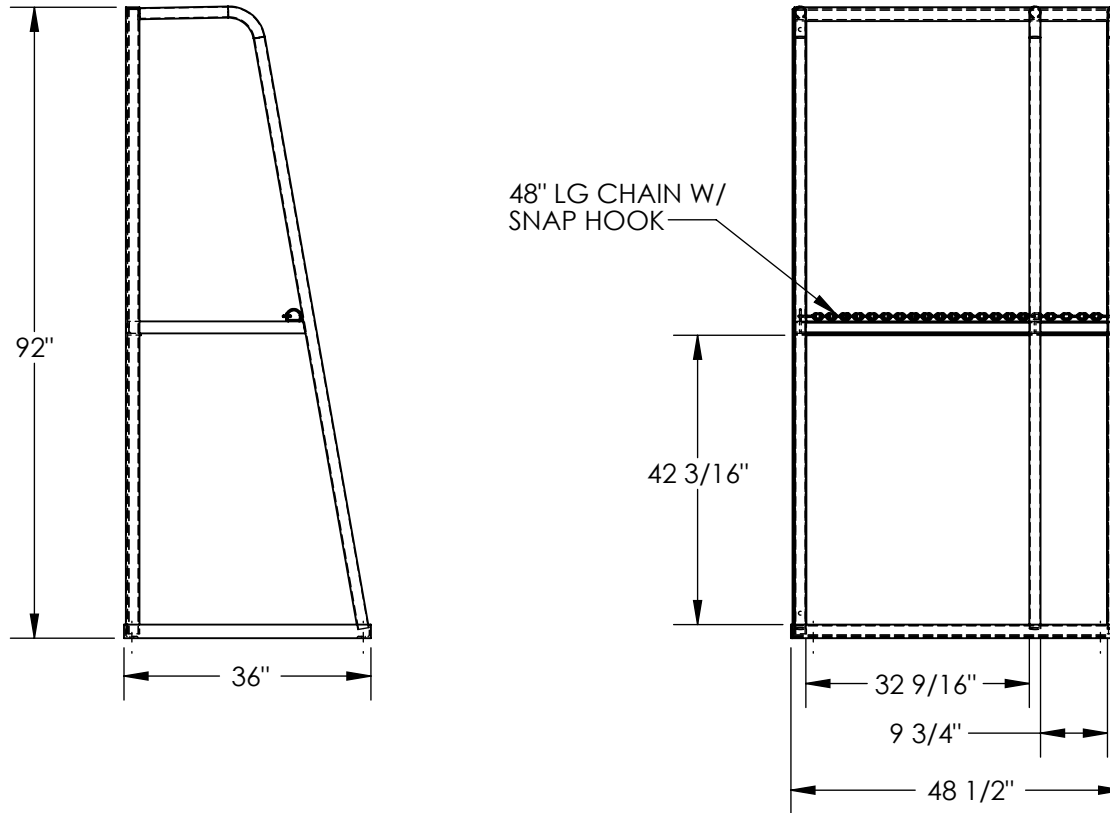

DIMENSION TOLERANCE 1/4"

I, THE UNDERSIGNED, AGREE THAT THE PRODUCT AS REPRESENTED SATISFIES DESIGN AND DIMENSION REQUIREMENTS. I ALSO ACKNOWLEDGE MY DUTY TO CONFIRM PRODUCT AND INSTALLATION COMPLIANCE WITH ALL APPLICABLE FEDERAL, STATE AND LOCAL REGULATIONS AND STANDARDS.

ANY MODIFIED UNITS ARE NON-RETURNABLE

As drawn As marked

Signed: _____ Date: _____

Printed Name: _____

LEAD TIME WILL START UPON RECEIPT OF SIGNED APPROVAL DRAWING

APPROVAL

STANDARD FEATURES

- MODEL NUMBER IS: SSRT-47-HP-WB-3
- CAPACITY IS: 1,500 LBS. PER BAY
- OVERALL WIDTH IS: 48 1/2"
- OVERALL DEPTH IS: 36"
- OVERALL HEIGHT IS: 92"
- 2 STORAGE BAYS; 9 3/4" AND 32 9/16" BETWEEN BAYS
- SUPPLIED WITH LAG DOWN POINTS WITH Ø9/16" HOLES
- ALL STEEL CONSTRUCTION
- 48" LG CHAIN W/ SNAP HOOKS AT EACH END
- TOUGH BAKED IN POWDER COATED BLUE FINISH

SPECIAL FEATURES

NONE

FOR INTERNAL USE ONLY
PROJECT SIGN OFF

SALES	
ENG.	
FAB.	
POWER	

DISTRIBUTOR'S NAME:		P.O.#
VESTIL MANUFACTURING		X
DRAWN BY:	DATE:	W.O.#
JWW	7/27/20	X
REFERENCE:	SCALE:	SALES:
X	1:28	X
QUOTED LEAD TIME:	QUOTE #	FILE NAME:
X	X	31-007-320