

TRASH CAN CART - TH-CART-64

APPROX WEIGHT: 227.81 lbs.
DOES NOT INCLUDE WEIGHT OF POWER OR PACKAGING!!!

*** ANY ADDITIONS, DELETIONS, OR OMISSIONS MUST BE CORRECTED ON THIS DRAWING AS THIS DRAWING WILL BE CONSIDERED ALL INCLUSIVE ***

ALL GRAPHICS PROVIDED ARE FOR REFERENCE ONLY. IF CERTAIN DIMENSIONS ARE CRITICAL PLEASE VERIFY THOSE DIMENSIONS WITH YOUR SALESPERSON

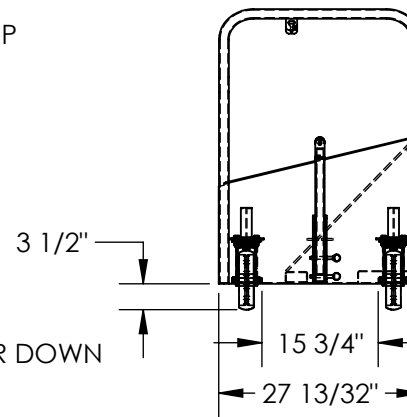
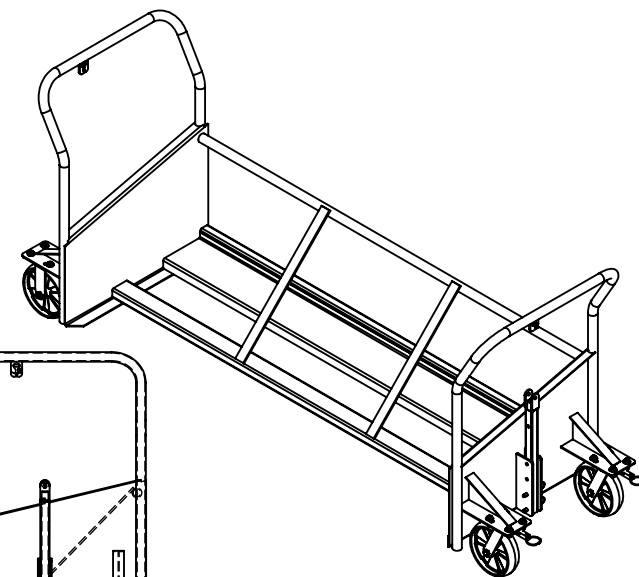
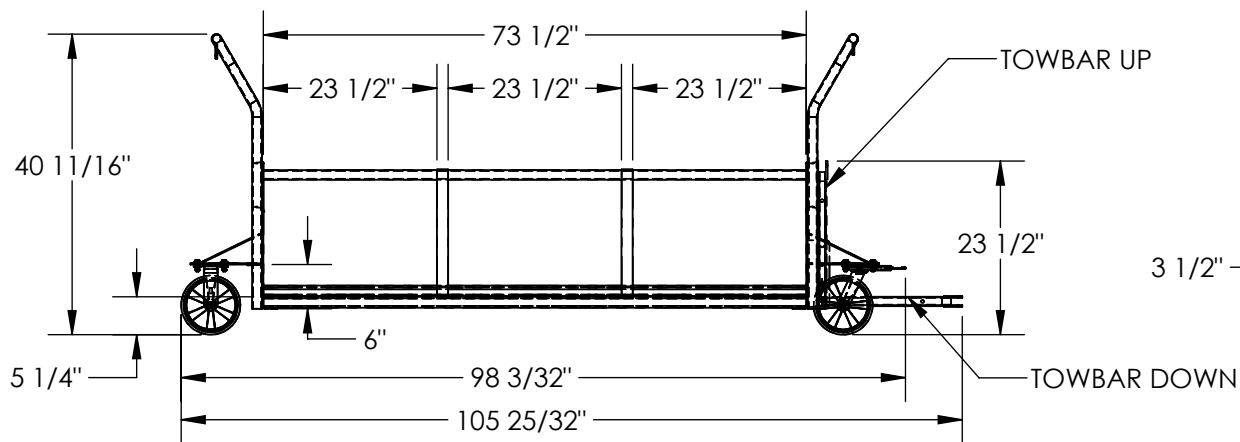
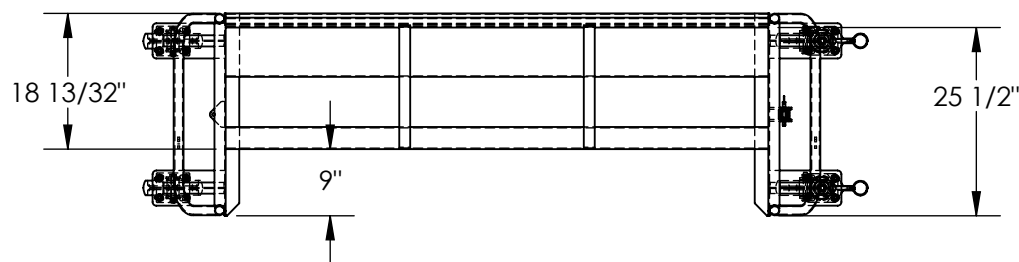

DIMENSION TOLERANCE ± 1/4"

STANDARD FEATURES

- MODEL NUMBER IS: TH-CART-64
- OVERALL WIDTH IS: 27 13/32"
- USABLE WIDTH IS: 18 13/32"
- OVERALL LENGTH IS: 105 25/32"
- USABLE LENGTH IS: 23 1/2"
- OVERALL HEIGHT IS: 40 11/16"
- MAX CAPACITY IS: UP TO (3) 64 GALLON TRASH CANS
- TOW BAR CAN BE ADJUSTED VERTICALLY IN 2 1/2" INCREMENTS
- TOW BAR HAS A FULLY EXTENDED LENGTH OF 30 7/8"
- TOW BAR HAS A FULLY RETRACTED LENGTH OF 19 5/8"
- RECEPTACLE RESTRAINT CHAIN NOT SHOWN: Ø3/16" x 100" LONG
- PUSH HANDLES ON EACH END
- (2) RIGID AND (2) SWIVEL CASTERS
- MULTIPLE UNITS MAY BE CONNECTED END-TO-END FOR TOWING
- WELDED STEEL CONSTRUCTION
- DURABLE BAKED IN POWDER COATED BLACK FINISH

SPECIAL FEATURES

NONE

APPROVAL

I, THE UNDERSIGNED, AGREE THAT THE PRODUCT AS REPRESENTED SATISFIES DESIGN AND DIMENSION REQUIREMENTS. I ALSO ACKNOWLEDGE MY DUTY TO CONFIRM PRODUCT AND INSTALLATION COMPLIANCE WITH ALL APPLICABLE FEDERAL, STATE AND LOCAL REGULATIONS AND STANDARDS.

UNITS REQUIRING APPROVAL DRAWINGS OR MODIFIED ARE NON-RETURNABLE

As drawn As marked

Signed: _____ Date: _____

Printed Name: _____

LEAD TIME WILL START UPON RECEIPT OF SIGNED APPROVAL DRAWING

DISTRIBUTOR'S NAME:		P.O.#
VESTIL MANUFACTURING		X
DRAWN BY: A. HUGHES		W.O.#
DATE: 03/27/2012		X
REFERENCE: X	SCALE: 1:26	SALES: X
QUOTED LEAD TIME: X	QUOTE # X	FILE NAME:
		16-007-321