

SINGLE SCISSOR LIFT & TILT TABLE - UNI-4848-4

APPROX WEIGHT: 701.08 lbs.
DOES NOT INCLUDE WEIGHT OF POWER OR PACKAGING!!!

*** ANY ADDITIONS, DELETIONS, OR OMISSIONS MUST BE CORRECTED ON THIS DRAWING AS THIS DRAWING WILL BE CONSIDERED ALL INCLUSIVE ***

ALL GRAPHICS PROVIDED ARE FOR REFERENCE ONLY. IF CERTAIN DIMENSIONS ARE CRITICAL PLEASE VERIFY THOSE DIMENSIONS WITH YOUR SALESPERSON

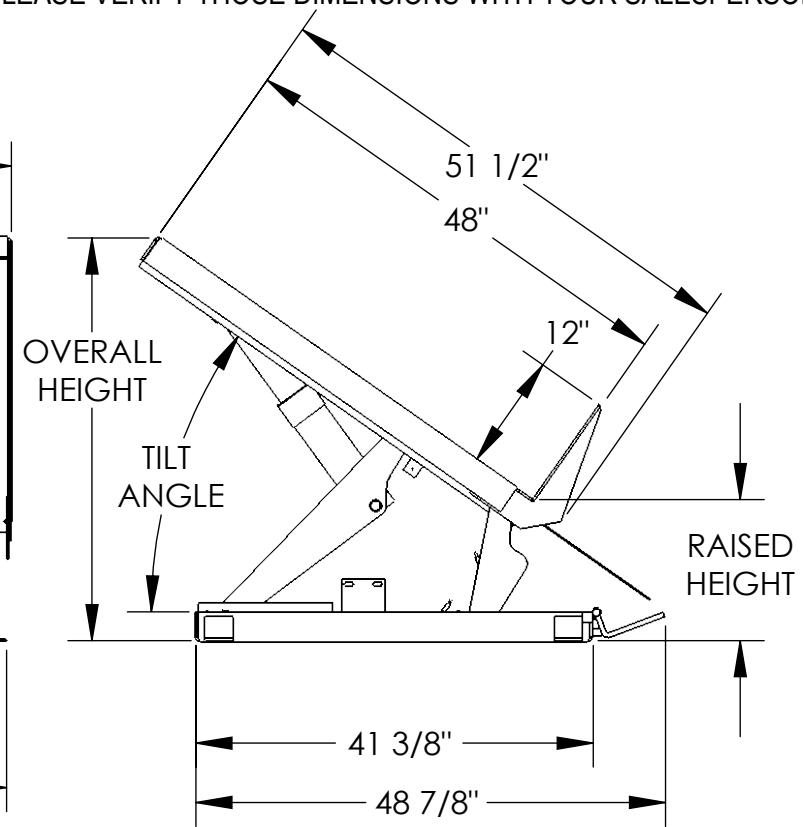
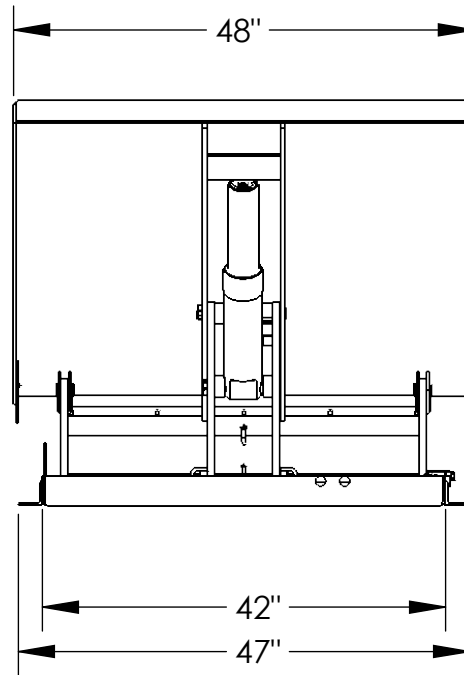
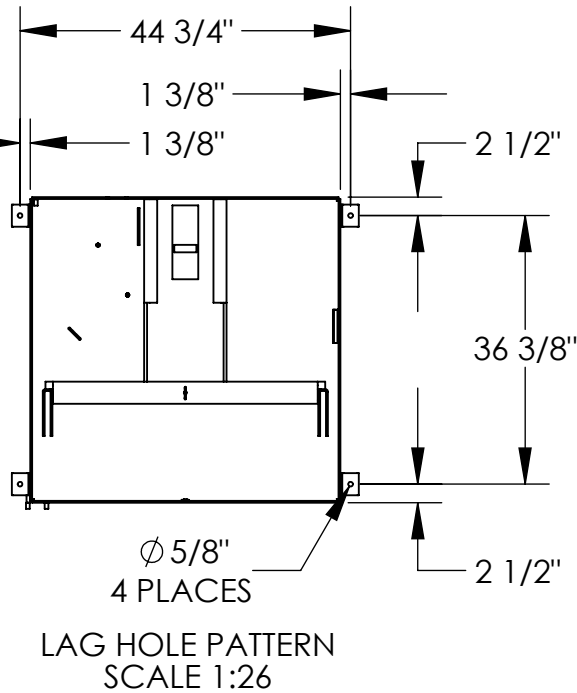

STANDARD FEATURES

MODEL NUMBER IS: UNI-4848-4
CAPACITY: 4,000 LBS. EVENLY DISTRIBUTED
SEQUENCE 1: RAISED HEIGHT: 14 3/4", TILT ANGLE 35°
OVERALL HEIGHT: 42"
SEQUENCE 2: RAISED HEIGHT 11 3/4", TILT ANGLE: 40°
OVERALL HEIGHT 42 1/4"
LEVEL HEIGHT: 8"
DECK SIZE: 48" W X 48" L WITH 12" LIP
INTEGRAL MAINTENANCE LOCK
ADJUSTABLE UPPER TRAVEL LIMIT SWITCH
UNIT MUST BE LAGGED TO THE FLOOR
DURABLE LIQUID PAINT BLUE FINISH

SPECIAL FEATURES

NONE

PLEASE CIRCLE SPECIFICATIONS:

| | | | |
|----------------------------|--|--|---|
| POWER | <input checked="" type="checkbox"/> AC | <input type="checkbox"/> DC (12V) | <input type="checkbox"/> AIR/OIL |
| MOTOR VOLTAGE | <input type="checkbox"/> 115 | <input type="checkbox"/> 208 | <input checked="" type="checkbox"/> 230 |
| DEDICATED CIRCUIT REQUIRED | | | |
| MOTOR PHASE | <input type="checkbox"/> SINGLE | <input type="checkbox"/> THREE | |
| CONTROL | <input type="checkbox"/> HAND | <input type="checkbox"/> FOOT | |
| * BATTERY CHRG. | <input type="checkbox"/> REMOTE | <input checked="" type="checkbox"/> ON-BOARD | |
| * CHRG. INDICATOR | <input type="checkbox"/> YES | <input type="checkbox"/> NO | |

* AVAILABLE AT ADDITIONAL COST

APPROVAL

DIMENSION TOLERANCE ± 1/4"

I, THE UNDERSIGNED, AGREE THAT THE PRODUCT AS REPRESENTED SATISFIES DESIGN AND DIMENSION REQUIREMENTS. I ALSO ACKNOWLEDGE MY DUTY TO CONFIRM PRODUCT AND INSTALLATION COMPLIANCE WITH ALL APPLICABLE FEDERAL, STATE AND LOCAL REGULATIONS AND STANDARDS.

ANY MODIFIED UNITS ARE NON-RETURNABLE

[] As drawn [] As marked

Signed: _____ Date: _____

Printed Name: _____

LEAD TIME WILL START UPON RECEIPT OF SIGNED APPROVAL DRAWING

| | | |
|----------------------|-------------|------------|
| DISTRIBUTOR'S NAME: | | P.O.# |
| VESTIL MANUFACTURING | | X |
| DRAWN BY: A.FORD | | W.O.# |
| DATE: 8/10/07 | | X |
| REFERENCE: X | SCALE: 1:20 | SALES: X |
| QUOTED LEAD TIME: X | QUOTE # | FILE NAME: |
| | X | 03-007-017 |