

**VHPS-2000-AA-17 (MANUAL HYDRAULIC HAND PUMP STACKER - ADJUSTABLE FORKS/ADJUSTABLE LEGS)**

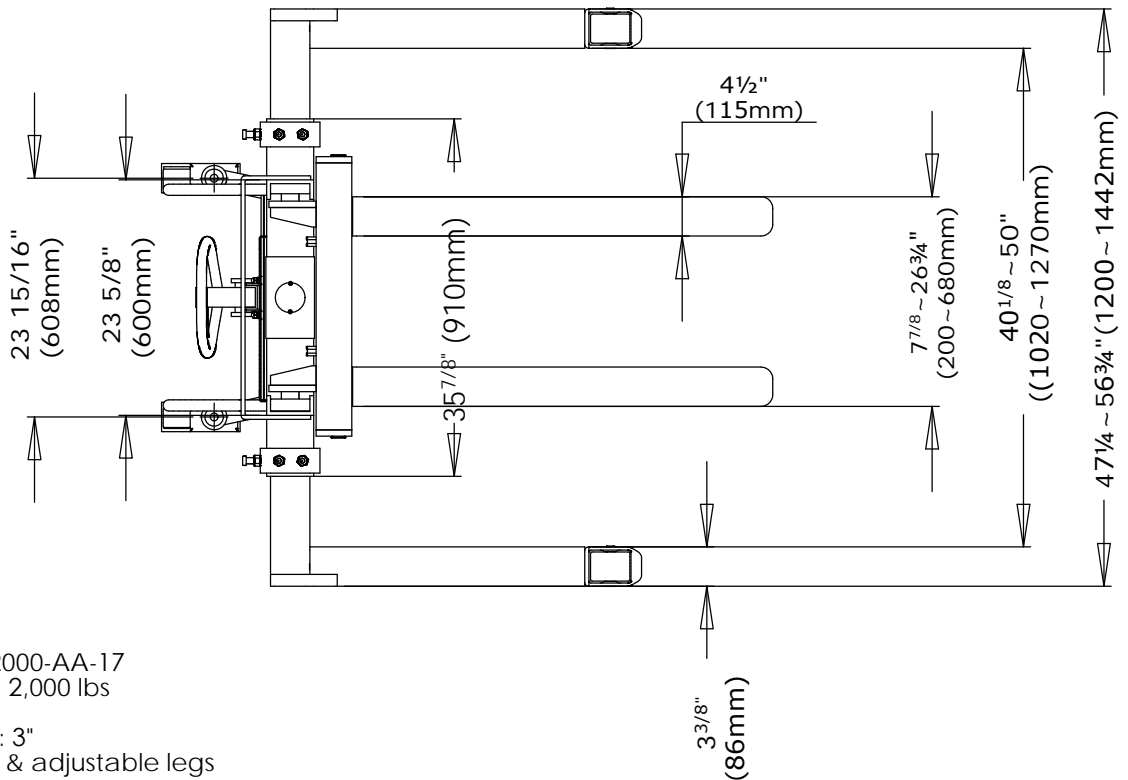
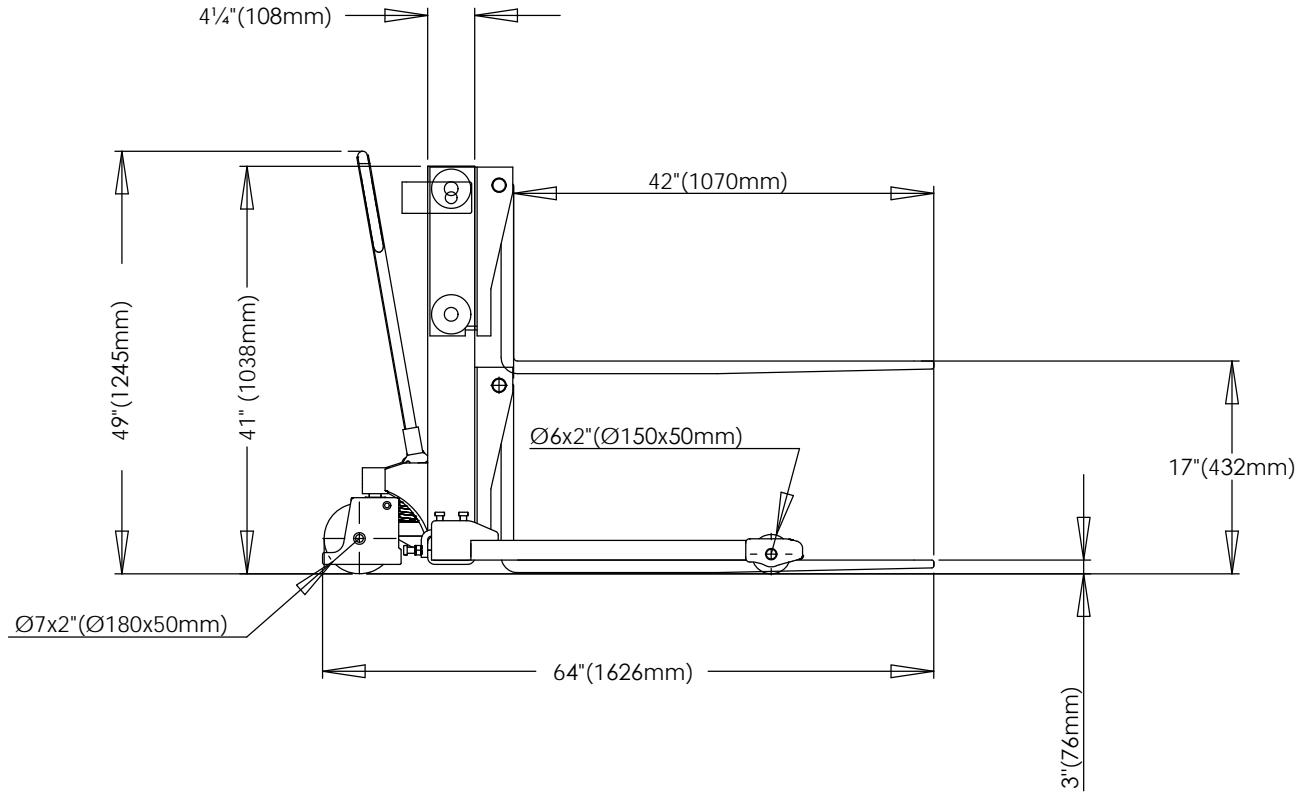

**Specifications**

- \*Model # VHPS-2000-AA-17
- \*Capacity (UDL): 2,000 lbs
- \*Lift height: 17"
- \*Lowered height: 3"
- \*Adjustable forks & adjustable legs
- \*Single mast
- \*Number of pumps to raise to maximum height: 21
- \*7/8" stroke per pump
- \*Down time loaded/unloaded: 6/5 secs
- \*Overall mast height: 41"
- \*Steering wheel: Ø7x2"
- \*Front wheel: Ø6x2"

<b>VESTIL MANUFACTURING CORP.</b>		
<b>DRAWN BY: TM</b>	<b>DATE:08/31/15</b>	
Reference:		DRWG./FILE NAME: VHPS-2000-AA-18