

MANUAL HAND PUMP STACKER (ADJUSTABLE FORKS OVER ADJUSTABLE LEGS)- VHPS-3000-AA-17 APPROX WEIGHT: lbs. *DOES NOT INCLUDE WEIGHT OF POWER OR PACKAGING!!!*

*** ANY ADDITIONS, DELETIONS, OR OMISSIONS MUST BE CORRECTED ON THIS DRAWING AS THIS DRAWING WILL BE CONSIDERED ALL INCLUSIVE ***
 ALL GRAPHICS PROVIDED ARE FOR REFERENCE ONLY. IF CERTAIN DIMENSIONS ARE CRITICAL PLEASE VERIFY THOSE DIMENSIONS WITH YOUR SALESPERSON

STANDARD FEATURES

- MODEL NUMBER IS: VHPS-3000-AA-17
- CAPACITY IS: 3,000 lbs
- OVERALL WIDTH IS: 60 1/4"
- OVERALL LENGTH IS: 48"
- OVERALL HEIGHT IS: 47 1/4"
- FORK LENGTH IS: 42"
- LOWERED FORK HEIGHT IS: 2 5/8"
- RAISED FORK HEIGHT IS: 17"
- TOUGH BAKED IN POWDER COATED BLACK AND YELLOW FINISH

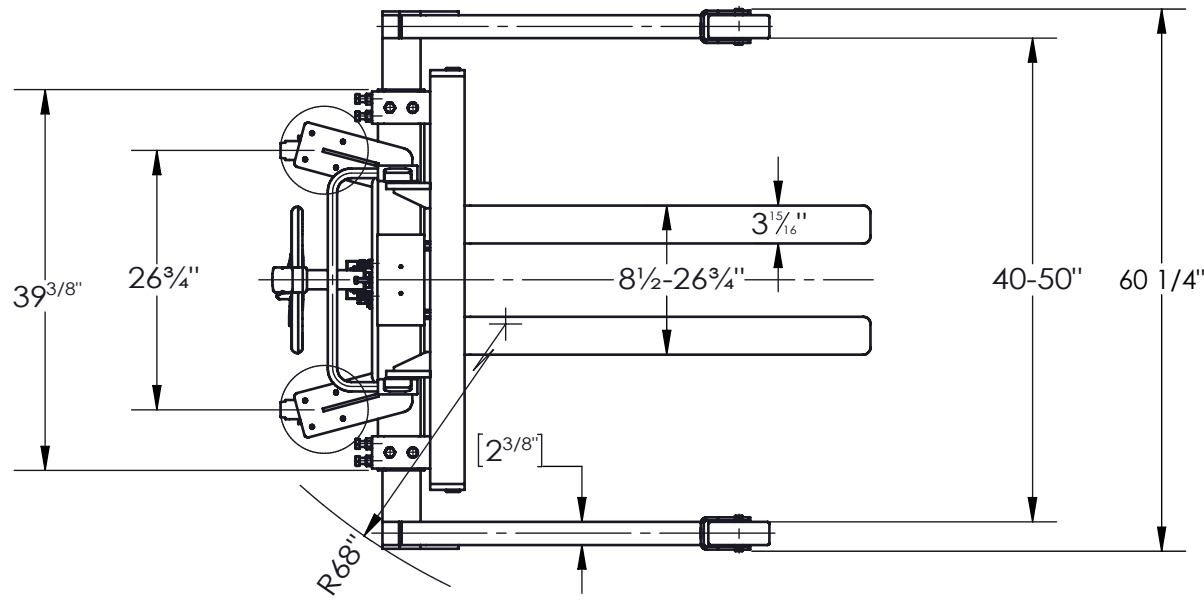
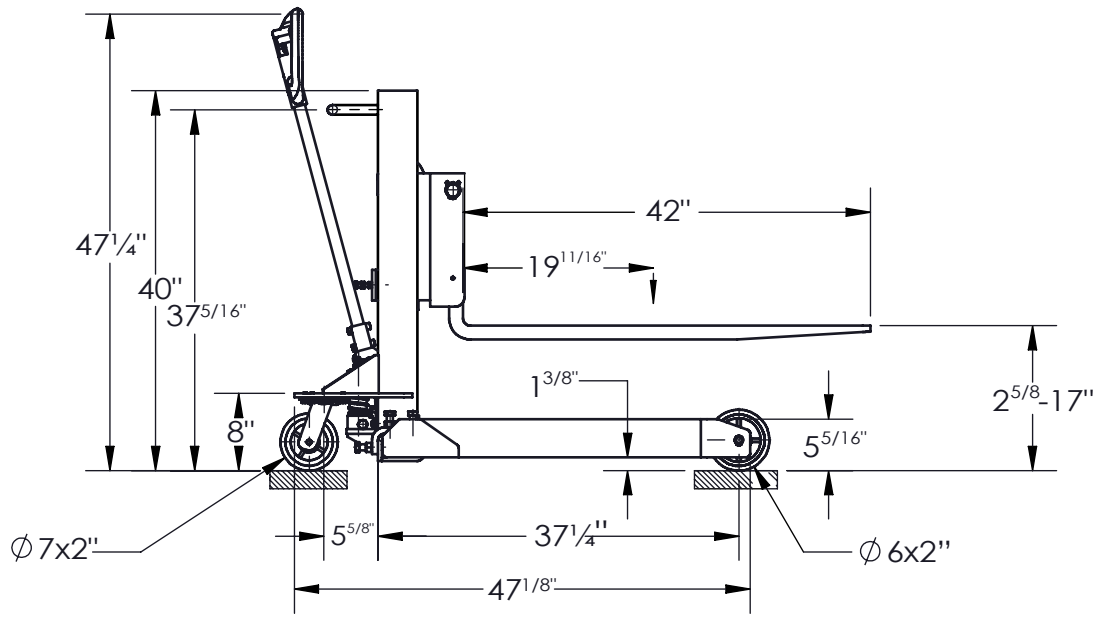

SPECIAL FEATURES

NONE

DIMENSION TOLERANCE $\pm 1/2''$

APPROVAL

I, THE UNDERSIGNED, AGREE THAT THE PRODUCT AS REPRESENTED SATISFIES DESIGN AND DIMENSION REQUIREMENTS. I ALSO ACKNOWLEDGE MY DUTY TO CONFIRM PRODUCT AND INSTALLATION COMPLIANCE WITH ALL APPLICABLE FEDERAL, STATE AND LOCAL REGULATIONS AND STANDARDS.
UNITS REQUIRING APPROVAL DRAWINGS OR MODIFIED ARE NON-RETURNABLE
 As drawn As marked

Signed: _____ Date: _____
 Printed Name: _____

LEAD TIME WILL START UPON RECEIPT OF SIGNED APPROVAL DRAWING

DISTRIBUTOR'S NAME:		P.O.#
VESTIL MANUFACTURING		X
DRAWN BY: TM		W.O.#
DATE: 03/14/2019		X
REFERENCE: X	SCALE: NTS	SALES: X
QUOTED LEAD TIME: X	QUOTE #	FILE NAME:
	X	VHPS-3000-AA-17