

PORTABLE ALUM. VEHICLE TWIN RAMPS - VTR-5.5-14-16

APPROX WEIGHT: 464.93 lbs.
DOES NOT INCLUDE WEIGHT OF POWER OR PACKAGING!!!

*** ANY ADDITIONS, DELETIONS, OR OMISSIONS MUST BE CORRECTED ON THIS DRAWING AS THIS DRAWING WILL BE CONSIDERED ALL INCLUSIVE ***

ALL GRAPHICS PROVIDED ARE FOR REFERENCE ONLY. IF CERTAIN DIMENSIONS ARE CRITICAL PLEASE VERIFY THOSE DIMENSIONS WITH YOUR SALESPERSON

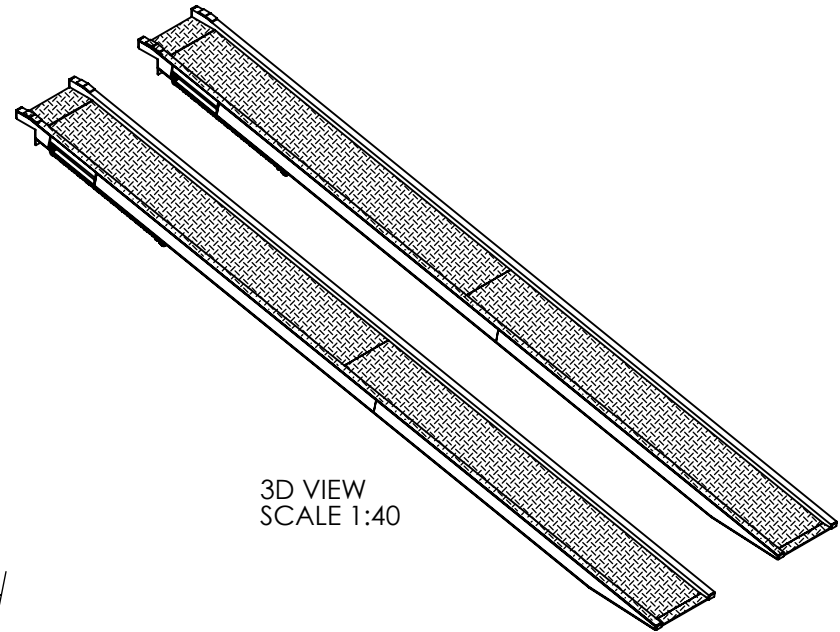
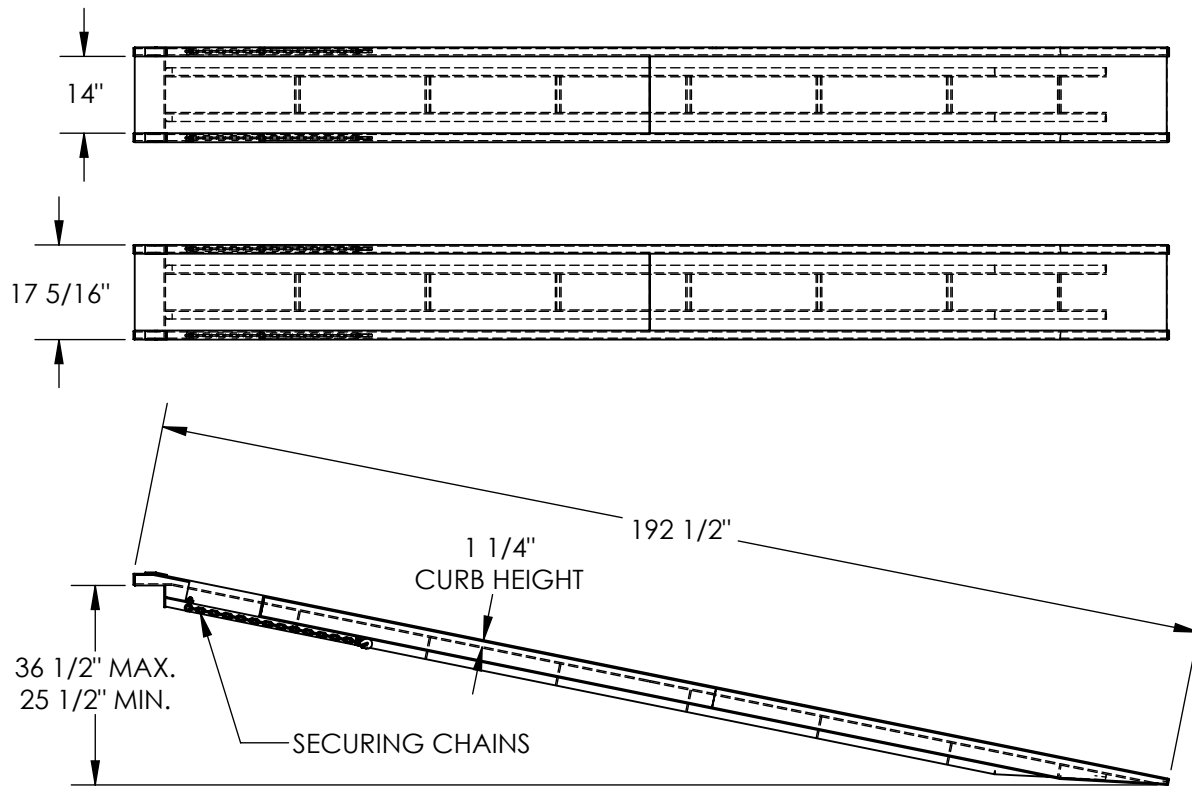

DIMENSION TOLERANCE ± 1/4"

STANDARD FEATURES

MODEL NUMBER IS VTR-5.5-14-16
OVERALL WIDTH IS 17 5/16"
USABLE RAMP WIDTH IS 14"
LENGTH IS 192 1/2"
MAX. WORKING HEIGHT IS 36 1/2"
MIN. WORKING HEIGHT IS 25 1/2"
MAX. LOAD CAPACITY (PER PAIR) IS 5,500 LBS.
1 1/4" CURB HEIGHT
INCLUDES 2 SECURING CHAINS
WELDED ALUMINUM CONSTRUCTION

SPECIAL FEATURES

NONE

FOR INTERNAL USE ONLY PROJECT SIGN OFF	
SALES	
ENG.	
FAB.	
POWER	

A P P R O V A L	I, THE UNDERSIGNED, AGREE THAT THE PRODUCT AS REPRESENTED SATISFIES DESIGN AND DIMENSION REQUIREMENTS. I ALSO ACKNOWLEDGE MY DUTY TO CONFIRM PRODUCT AND INSTALLATION COMPLIANCE WITH ALL APPLICABLE FEDERAL, STATE AND LOCAL REGULATIONS AND STANDARDS.	
	ANY MODIFIED UNITS ARE NON-RETURNABLE	
	[] As drawn [] As marked	
	Signed: _____ Date: _____	
Printed Name: _____		
LEAD TIME WILL START UPON RECEIPT OF SIGNED APPROVAL DRAWING		

DISTRIBUTOR'S NAME:		P.O.#
VESTIL MANUFACTURING		X
DRAWN BY: TJM	DATE: 11/14/14	W.O.#
REFERENCE: X	SCALE: 1:35	X
QUOTED LEAD TIME: X	QUOTE #	FILE NAME:
	X	18-007-304