

PORTABLE ALUM. VEHICLE TWIN RAMPS - VTR-6-14-14

APPROX WEIGHT: 406.61 lbs.
 DOES NOT INCLUDE WEIGHT OF POWER OR PACKAGING!!!

*** ANY ADDITIONS, DELETIONS, OR OMISSIONS MUST BE CORRECTED ON THIS DRAWING AS THIS DRAWING WILL BE CONSIDERED ALL INCLUSIVE ***

ALL GRAPHICS PROVIDED ARE FOR REFERENCE ONLY. IF CERTAIN DIMENSIONS ARE CRITICAL PLEASE VERIFY THOSE DIMENSIONS WITH YOUR SALESPERSON

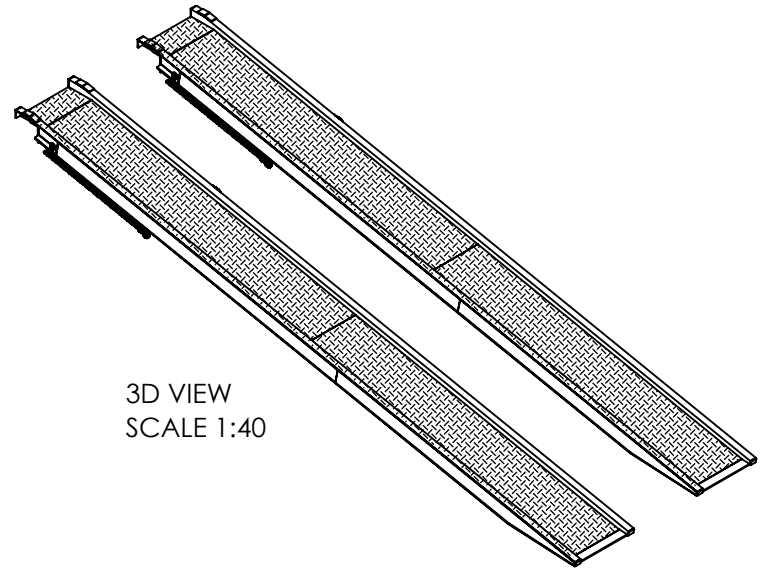
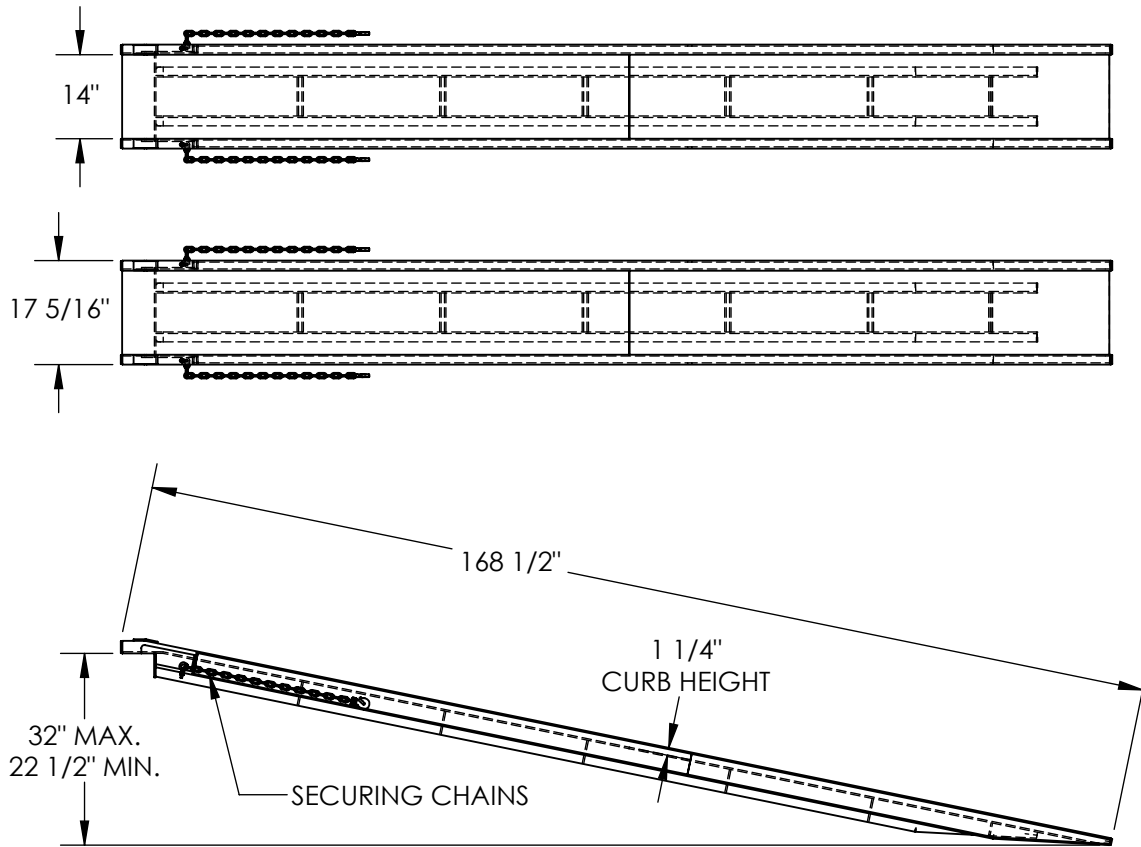

DIMENSION TOLERANCE ± 1/4"

STANDARD FEATURES

- MODEL NUMBER IS VTR-6-14-14
- OVERALL WIDTH IS 17 5/16"
- USABLE WIDTH IS 14"
- OVERALL LENGTH IS 168 1/2"
- MAX. WORKING HEIGHT IS 32"
- MIN. WORKING HEIGHT IS 22 1/2"
- MAX. LOAD CAPACITY (PER PAIR) IS 6,000 LBS.
- 1 1/4" CURB HEIGHT
- INCLUDES 2 SECURING CHAINS PER RAMP
- WELDED ALUMINUM CONSTRUCTION

SPECIAL FEATURES

NONE

I, THE UNDERSIGNED, AGREE THAT THE PRODUCT AS REPRESENTED SATISFIES DESIGN AND DIMENSION REQUIREMENTS. I ALSO ACKNOWLEDGE MY DUTY TO CONFIRM PRODUCT AND INSTALLATION COMPLIANCE WITH ALL APPLICABLE FEDERAL, STATE AND LOCAL REGULATIONS AND STANDARDS.

ANY MODIFIED UNITS ARE NON-RETURNABLE

[] As drawn [] As marked

Signed: _____ Date: _____

Printed Name: _____

LEAD TIME WILL START UPON RECEIPT OF SIGNED APPROVAL DRAWING

DISTRIBUTOR'S NAME:		P.O.#
VESTIL MANUFACTURING		X
DRAWN BY: TJM		DATE: 12/05/17
REFERENCE: X		SCALE: 1:32
QUOTED LEAD TIME: X		QUOTE # X
		FILE NAME: 18-007-303

FOR INTERNAL USE ONLY PROJECT SIGN OFF	
SALES	
ENG.	
FAB.	
POWER	